

MITSUBISHI SERVO SYSTEM CONTROLLERS

SERVO SYSTEM CONTROLLER





Motion control in harmony with man, machine and the environment



Most-advanced

SSCNET III/H compatible Motion controller
Q173DSCPU/Q172DSCPU

SSCNET III/H compatible Stand-Alone
Motion controller
Q170MSCPU/Q170MSCPU-S1



Pursuing Ease of use

SSCNET III/H compatible Simple Motion module
QD77MS16/QD77MS4/QD77MS2

CC-Link IE Field Network Simple Motion module
QD77GF16

SSCNET III/H compatible Simple Motion module
LD77MS16/LD77MS4/LD77MS2

New-generation Servo System Controller Debut

The servo system controllers have advanced to be safer for people and more flexible for various applications with our reliable technology. We are proudly offering our products, which not only having excellent functions but also are user and environmentally friendly.

Harmony with machine, man, and the environment.

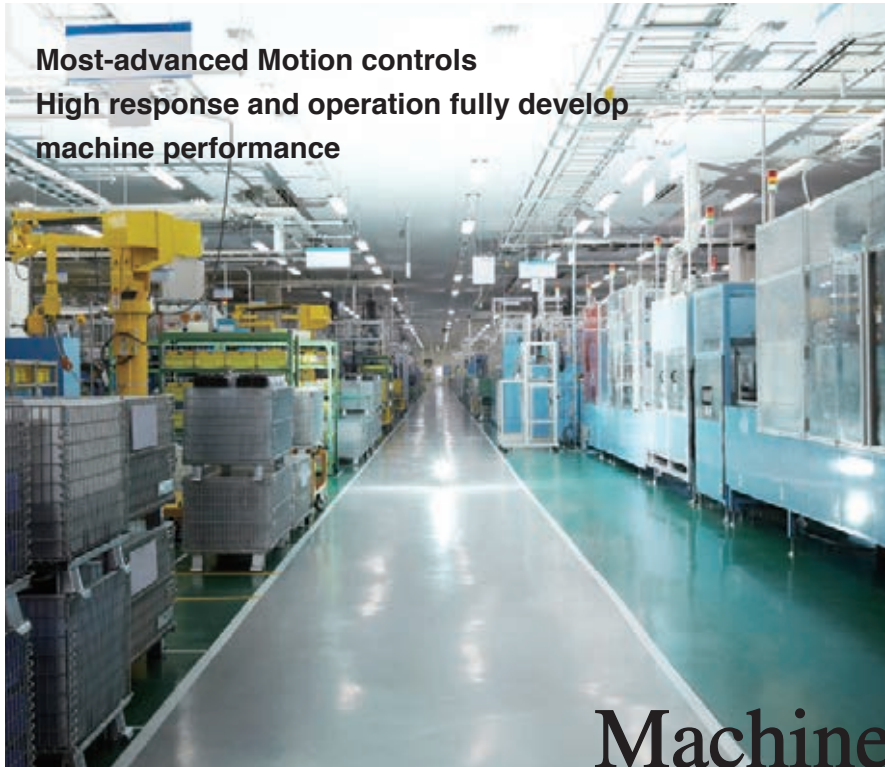

Most-advanced Motion controls
High response and operation fully develop
machine performance

Machine

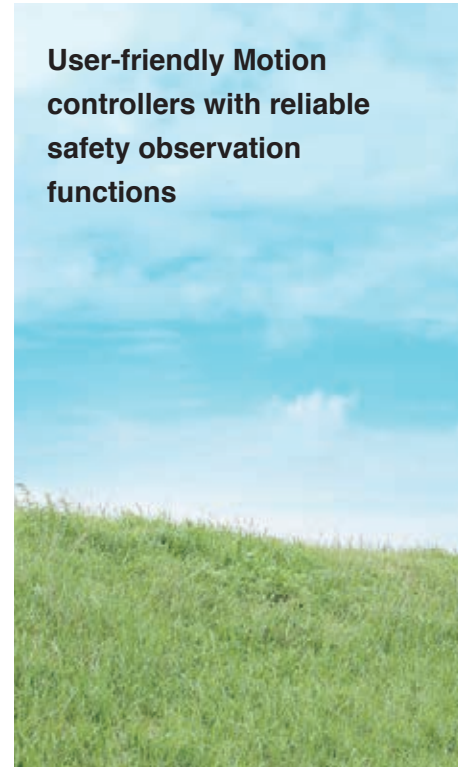

User-friendly Motion controllers with reliable safety observation functions

Expanding the applications

Now that High-mix Low-volume production is a big trend in the market, the Motion controllers are expected to be used in various applications. The Motion controllers and the Simple Motion modules are capable of various controls such as positioning control, speed control, torque control, tightening & press-fit control, synchronous control and cam control. They are applied to various machines such as X-Y tables, unwinding machines, packing machines and filling machines.

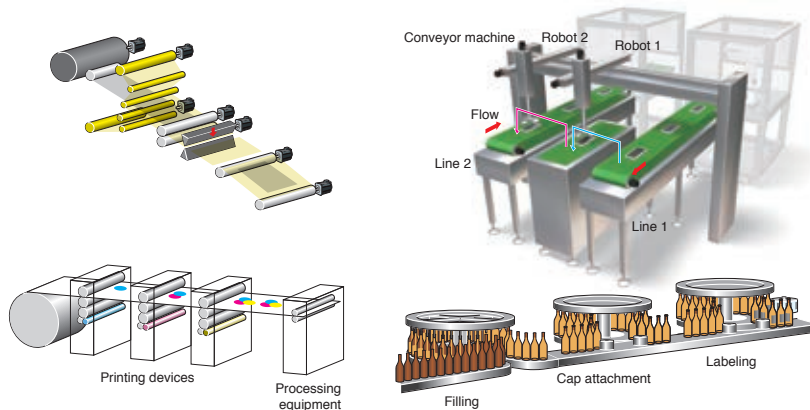

Reliable Safety observation function

Ensuring safety in the production site is an absolute requirement; therefore devices must comply with international safety standards. Q17nDSCPU is equipped with functions which achieve Performance Level d (PLd) as standard.

User-friendly engineering environment

Pursuing Ease of use. The powerful functions are aimed at creating a more user-friendly engineering environment with the enhanced design and debugging efficiency, reduced downtime, and data protection, etc.



Motion controller highly compatible with prior models

The Motion controller and the Simple Motion module are highly compatible with the previous servo amplifiers and Motion controllers, so the existing projects and programs can continue to be used.

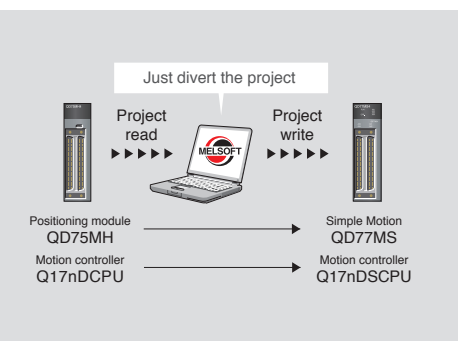

New approach for future Motion controls.

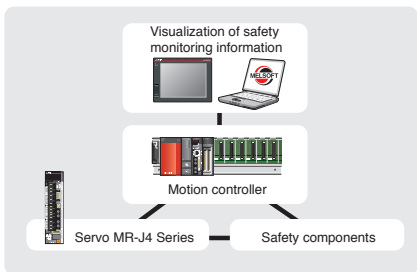

Safety components : Safety relay, CC-Link Safety compatible products, Contactor SD-Q Series

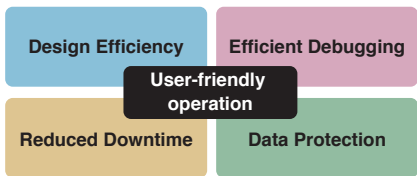

Servo visualization

For energy conservation, understanding the consumption of electric power is vital.

The Motion controller and the Simple Motion module have the “Optional data monitor function”. Information such as motor current value, power consumption and total power consumption of the servo amplifier and servo motor are available via the SSCNET III/H. You can check the information on the screen to save energy.

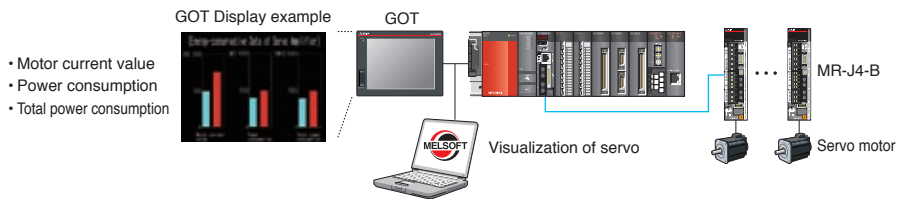

Reduced wiring and space saving

The servo system controller used with MR-J4 series servo amplifier can dramatically reduce wiring and save space. With the SSCNET III/H compatible servo amplifier, the number of wires is greatly reduced compared with the pulse train type. With the 3-axis servo amplifier, the installation space is reduced by approximately 30% compared with the MR-J3-B.

High compatibility with the previous controllers

Q17nDSCPU Motion controller and QD77MS Simple Motion module can utilize projects diverted from Q17nDSCPU Motion controller and QD75MH positioning module. There is no need to create new projects when replacing the modules.

High compatibility with the previous amplifiers

The SSCNET III/H compatible Motion controller and Simple Motion module can connect MR-J3-B SSCNET III compatible servo amplifiers, so you simply replace Q17nDCPU Motion controller or QD75MH Positioning modules with these new models. MR-J4-B SSCNET III/H compatible servo amplifier can also be used with MR-J3-B SSCNET III compatible servo amplifier in a same system. You can continue to use the previous servo amplifiers.

A complete system lineup to meet your production and manufacturing

Responding to expanding applications such as semiconductor and LCD manufacturing, packing machines, and cap tightening machines, coordinated with Mitsubishi Electric's other product lines such as displays and programmable controllers as well as servo amplifiers and Mitsubishi allows you to freely create an advanced servo system.

HUMAN MACHINE I/F

Graphic Operation Terminal



GOT2000/GOT1000 series

Personal computer



SOFTWARE



CONTROLLER



iQ Platform Programmable controller

Motion controller



SSCNET III/H compatible Motion controller

Q173DSCPU
Q172DSCPU

Stand-Alone Motion controller



SSCNET III/H compatible Stand-Alone Motion controller

Q170MSCPU
Q170MSCPU-S1

Programmable controller



MELSEC-L series

Simple Motion module



SSCNET III/H compatible Simple Motion module

LD77MS16
LD77MS4
LD77MS2

NETWORK

The new-generation optical network "SSCNET III/H" in pursuit of high response and reliability

SERVO AMPLIFIER

MR-J4-B/MR-J4W2-B/MR-J4W3-B



SSCNET III/H compatible servo amplifier

MR-J4-B
MR-J4-B-RJ



SSCNET III/H compatible 2-axis servo amplifier

MR-J4W2-B



SSCNET III/H compatible 3-axis servo amplifier

MR-J4W3-B

SERVO MOTOR

Rotary servo motor



Small capacity, low inertia
HG-KR series
Capacity: 50 to 750 W



Small capacity, ultra-low inertia
HG-MR series
Capacity: 50 to 750 W



Medium capacity, medium inertia
HG-SR series
Capacity: 0.5 to 7 kW



Medium/large capacity, low inertia
HG-JR series
Capacity: 0.5 to 55 kW



Medium capacity, ultra-low inertia
HG-RR series
Capacity: 1 to 5 kW



Medium capacity, flat type
HG-UR series
Capacity: 0.75 to 5 kW

SOLUTION



Mitsubishi Electric's integrated FA solution for achieving seamless information collaboration between information systems and control systems, and enabling lateral integration of production sites.



needs



Motion controllers and Simple Motion modules are flexibly servo motors via SSCNET III/H.

Motion Controller Engineering Software	MELSOFT MT Works2
Programmable Controller Engineering Software	MELSOFT GX Works2
Servo Setup Software	MELSOFT MR Configurator2
Capacity selection software	

Programmable controller	
<p>MELSEC-Q series MELSEC-QS/WS series</p>	
Simple Motion module	Simple Motion module
<p>SSCNET III/H compatible Simple Motion module QD77MS16 QD77MS4 QD77MS2</p>	<p>CC-Link IE Field Network Simple Motion module QD77GF16</p>

Ethernet-based Open Network CC-Link IE Field Network	
<p>MR-J4-B-RJ010 +MR-J3-T10</p> <p>CC-Link IE Field Network servo amplifier with Motion</p> <p>MR-J4-B-RJ010 +MR-J3-T10</p>	LOW-VOLTAGE SWITCHGEAR
Magnetic contactor MS-T	Molded-case circuit breaker WS-V

Linear servo motor	
<p>Core type LM-H3 series Rating: 70 to 960 N</p>	<p>Core type (natural/liquid cooling) LM-F series Rating: 300 to 3000 N (natural cooling) Rating: 600 to 6000 N (liquid cooling)</p>
<p>Core type with magnetic attraction counter-force LM-K2 series Rating: 120 to 2400 N</p>	<p>Coreless type LM-U2 series Rating: 50 to 800 N</p>
Direct drive motor	
 TM-RFM series Rating: 2 to 240 N·m	

I N D E X

	Solutions.....	P07	
Outline	Overview of Servo System Controller	P09	
Motion Controller	Motion Controller	P13	
	Features	P15	
	Engineering Software	P27	
	Specifications	P29	
Simple Motion	Simple Motion Module	P43	
	Features	P47	
	Engineering Software	P53	
	Specifications	P55	
Network	Network		
	SSCNETIII/H	P63	
	CC Link IE Field Network	P65	
	FA Integrated Network	P66	
Servo Amplifier	Servo Amplifier MELSERVO-J4	P67	
Engineering Environment	Engineering Environment	P71	
Production/Development System	Production/Development System	P77	
SSCNET Partner Association	SSCNET Partner Association	P78	
Global Support Network	Global Support Network	P79	
FA Products	FA Products	P82	
Warranty	Warranty	P86	

Mitsubishi Electric's integrated FA platform for achieving lateral integration of controllers & HMI, engineering environments and networks at production sites.

Our servo system controllers offering exceptional solutions for more advanced Motion control

CASE1 | Packing Machines (Advanced synchronous control, Cam control, Mark detection function) Q17nDSCPU QD77MS LD77MS
Q170MSCPU QD77GF

When the machine packs food, the whole process is synchronized by using synchronous control and cam control. The packing film is cut using the registration mark as a reference with the mark detection function.

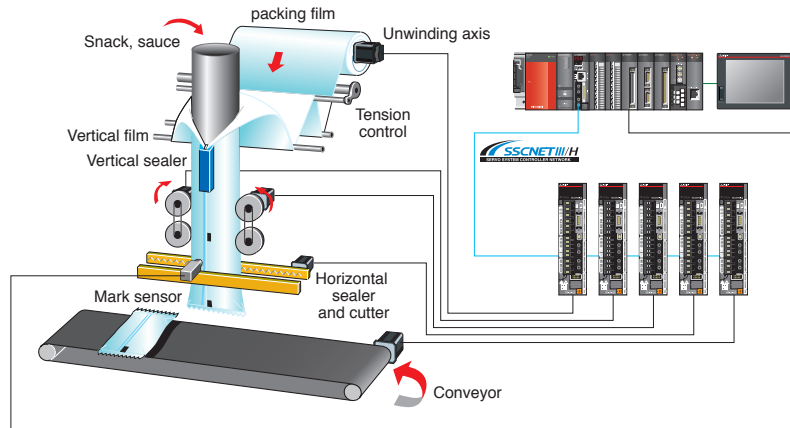

CASE2 | Conveyor Machines (Advanced S-curve acceleration/deceleration function) Q17nDSCPU
Q170MSCPU

Vibration is minimized and a short tact time is achieved with the advanced S-curve acceleration/deceleration function by setting the smooth acceleration period (Sin wave interval) and maximum acceleration period (Constant acceleration interval).

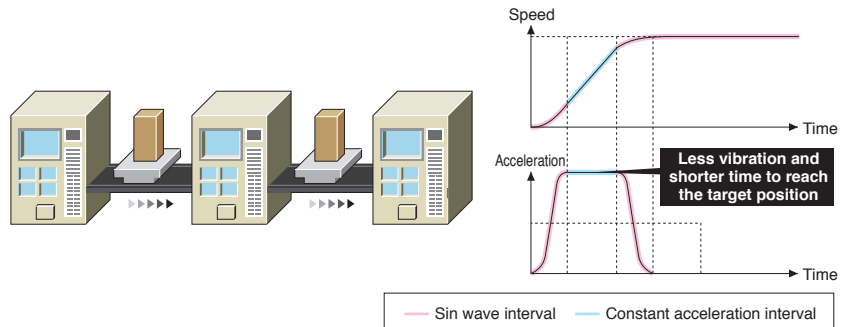

CASE3 | Alignment System (Ethernet connection, Vision system, Target position change function) Q17nDSCPU
Q170MSCPU

COGNEX Vision System is connected to the Motion CPU with Ethernet through the built-in PERIPHERAL I/F. Alignment time is reduced with the target position change function which uses the workpiece position data from the vision system for high-speed Motion control.

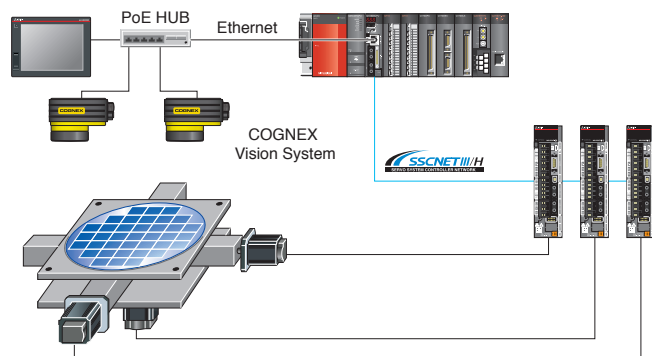

CASE4

Cap Tightening Machines (Position control, Torque control, Tightening & press-fit control)

Q17nDSCPU QD77MS LD77MS
Q170MSCPU

Position control can be switched to torque control or vice versa. "Tightening & press-fit control" is also available, switching to torque control without the motor stopping the movement during the positioning. Since the current position is controlled in any control modes, the positioning is carried out smoothly even after switching back to position control.

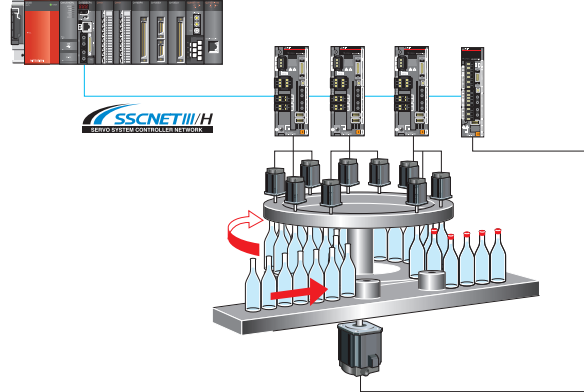

CASE5

Safety System (Safety signal comparison function)

Q17nDSCPU QD77MS LD77MS

A safety system is simply structured using the light curtain, forced stop button or safety fence, etc. The wiring for power shutoff between the Motion controller and the servo amplifier is no longer needed when MR-D30 functional safety unit is used.

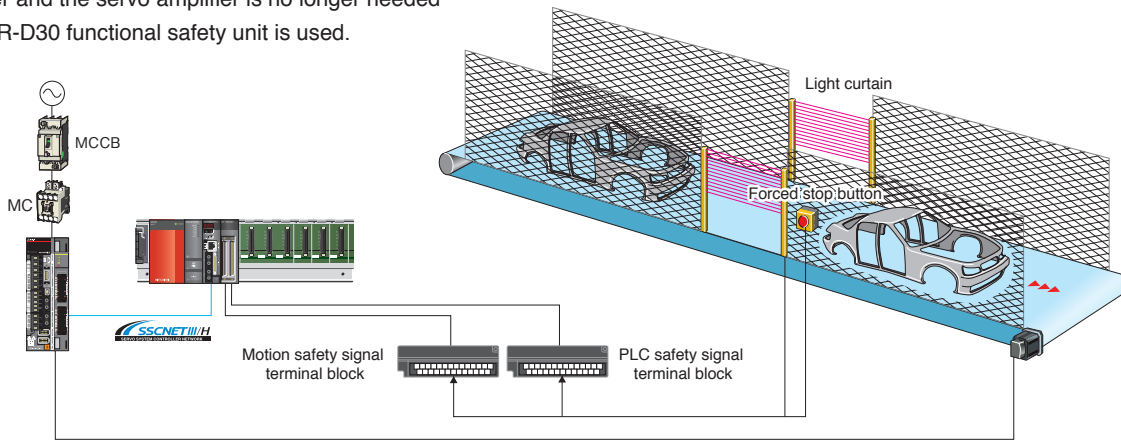

CASE6

Servo Visualization (Optional data monitor function)

Q17nDSCPU QD77MS LD77MS
Q170MSCPU

The motor current value, power consumption and total power consumption of the servo amplifier and servo motor via SSCNET III/H are visible on the user-designed graphic operation terminal screen. The ability to check the information helps you to save power.

[Display example]

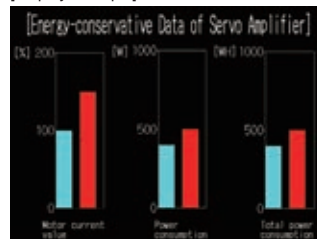

- Motor current value
- Power consumption
- Total power consumption

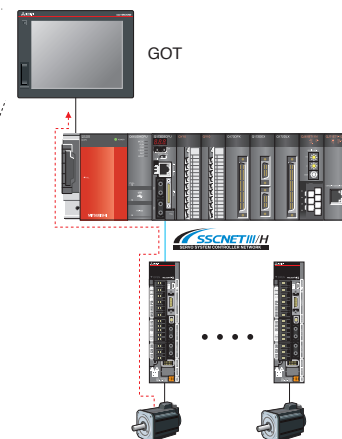

Coordinated with a wide range of applications and controls

Features of Motion Controller

The Motion controller is a CPU module used with PLC CPU for Motion control.

- Using Motion SFC program, the Motion CPU separately operates the controls from the PLC CPU.
- CPU loads are distributed by sharing tasks between Motion CPU and PLC CPU for advanced Motion control.
- Advanced Motion control is achieved, such as position follow-up and tandem operation.
- High-speed input and output are possible with direct management of various modules, such as I/O, analog, and high-speed counter.

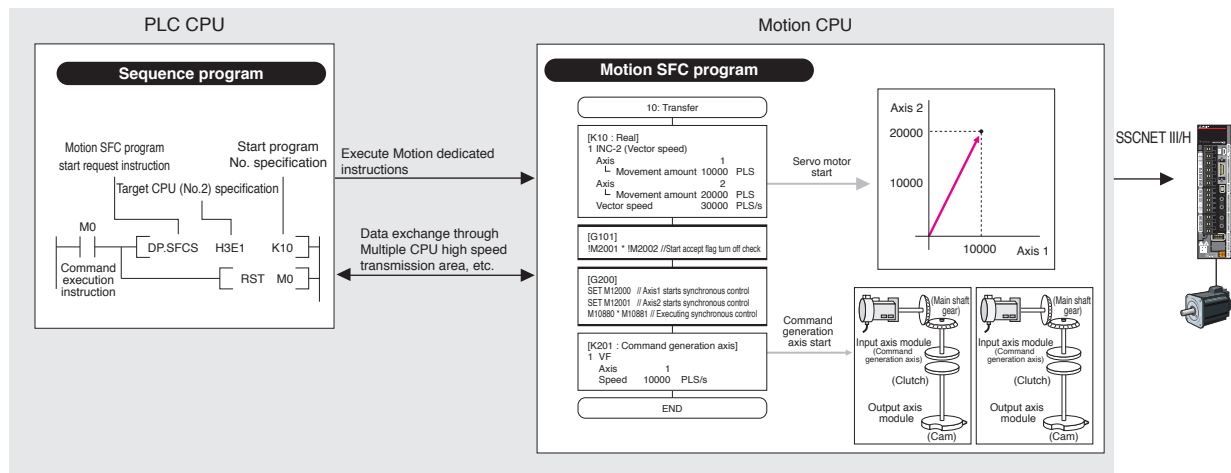

Advanced Motion control



SSCNET III/H compatible
MELSEC-Q series

Q173DSCPU
Q172DSCPU

- For a large or medium scale system
- Maximum number of controlled axes:
32 axes (Q173DSCPU), 16 axes (Q172DSCPU)
- A PLC CPU or a C Controller is selectable according to your application
- Up to 96 axes can be controlled by use of three modules of the Q173DSCPU
- Supports the safety observation function and the vision system



SSCNET III/H compatible
MELSEC-Q series

Q170MSCPU
Q170MSCPU-S1

- Highly cost-effective product for a small scale system
- Integrates a power supply, a PLC, and a Motion controller
- Maximum number of controlled axes: 16 axes
- The program capacity:
60k steps (Q170MSCPU-S1), 30k steps (Q170MSCPU)
- Supports the vision system





Features of Simple Motion Module

The Simple Motion module is an intelligent function module which performs positioning control by following the instructions of PLC CPU.

- The positioning functions are used in the same manner as those of the Positioning module.
- Linear interpolation control and other controls can be achieved easily just by writing positioning data to the buffer memory with sequence programs.
- Positioning/advanced synchronous/cam controls are performed with simple parameter setting and a start from a sequence program.
- Supports only MELSOFT GX Works2 as an engineering software.

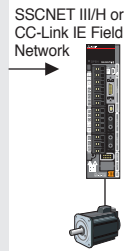
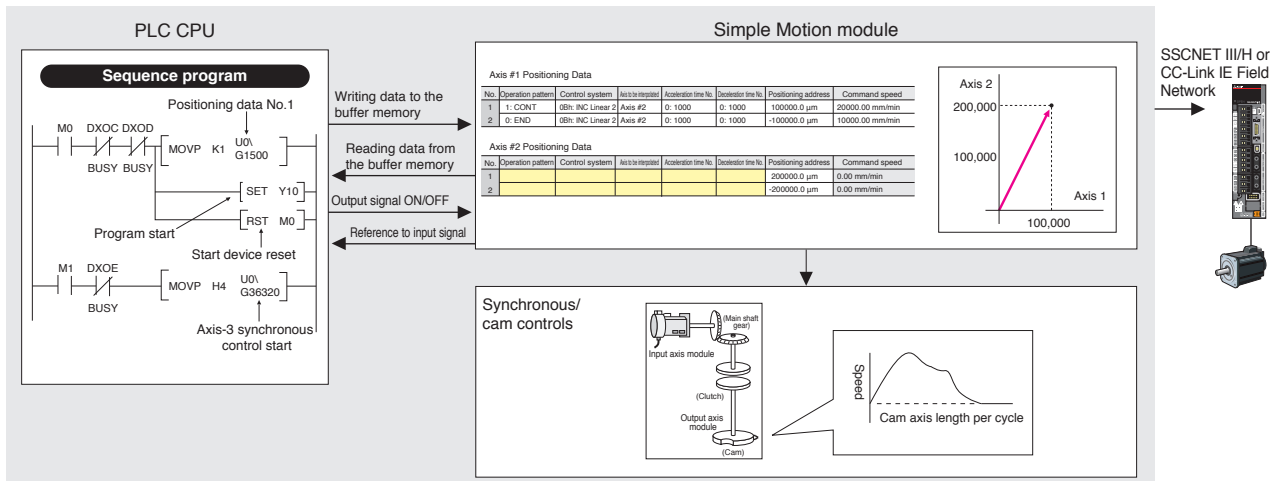

Advanced control but simple to use just like Positioning modules



SSCNET III/H compatible
MELSEC-Q series
QD77MS16
QD77MS4
QD77MS2



- For customers who need a module allowing user to use a wide-range of Motion controls - advanced synchronous control, cam control, speed-torque control (tightening & press-fit control), etc. - more easily just with the sequence programs.
- Maximum number of controlled axes:
16 axes (QD77MS16), 4 axes (QD77MS4), and 2 axes (QD77MS2)
- Equipped with all the functions of the QD75MH Positioning module



SSCNET III/H compatible
MELSEC-L series
LD77MS16
LD77MS4
LD77MS2



- For customers who need more compact and lower cost products
- Maximum number of controlled axes:
16 axes (LD77MS16), 4 axes (LD77MS4), and 2 axes (LD77MS2)
- Equipped with all the functions of the QD75MH Positioning module



















CC-Link IE Field Network compatible
MELSEC-Q series
QD77GF16



- For customers who prefer to use open network
- Maximum number of controlled axes: 16 axes
- Equipped with all the functions of the QD75MH Positioning module

Function Comparison of Motion Controller and Simple Motion Module

	Motion controller				Simple Motion module				
	Q173DSCPU Q172DSCPU		Q170MSCPU Q170MSCPU-S1		QD77MS16 QD77MS4 QD77MS2	LD77MS16 LD77MS4 LD77MS2	QD77GF16		
Module type	CPU module				Intelligent function module				
Servo amplifier	MR-J4-B 	MR-J4W2-B 	MR-J4W3-B 	MR-J4-B-RJ 	MR-J4-B 	MR-J4W2-B 	MR-J4W3-B 	MR-J4-B-RJ 	MR-J4-B-RJ010 + MR-J3-T10 
Servo motor									
Servo amplifier interface									
	2 systems 1 system		1 system		1 system				
Maximum number of control axes	32 axes 16 axes		16 axes		16 axes 4 axes 2 axes			16 axes	
Operation cycle	0.22 ms or more				0.88 ms or more				
Programmable controller	MELSEC-Q series 		Q03UD or equivalent Q06UDH or equivalent		MELSEC-Q series	MELSEC-L series	MELSEC-Q series		
Engineering environment	MT Works2		MR Configurator2 (Note-1)		GX Works2	MR Configurator2 (Note-1)			
Programming	Motion SFC				Point table				

(Note-1): MELSOFT MR Configurator2 is included in MELSOFT MT Works2.

SERVO SYSTEM CONTROLLER

■ Featured functions

	Motion controller		Simple Motion module		
	Q173DSCPU Q172DSCPU	Q170MSCPU Q170MSCPU-S1	QD77MS16 QD77MS4 QD77MS2	LD77MS16 LD77MS4 LD77MS2	QD77GF16
Control mode	<ul style="list-style-type: none"> Position control Torque control Synchronous control Advanced synchronous control 	<ul style="list-style-type: none"> Speed control Tightening & press-fit control Cam control 	<ul style="list-style-type: none"> Position control Torque control Advanced synchronous control 	<ul style="list-style-type: none"> Speed control Tightening & press-fit control ^(Note-1) Cam control 	
Positioning control	<ul style="list-style-type: none"> Linear interpolation Trajectory control Position follow-up control High-speed oscillation control 	<ul style="list-style-type: none"> Circular interpolation Helical interpolation Speed control with fixed position stop Speed/position switching control 	<ul style="list-style-type: none"> Linear interpolation Trajectory control Position/speed switching control 	<ul style="list-style-type: none"> Circular interpolation Speed/position switching control (ABS) Speed/position switching control (INC) 	
Acceleration/deceleration control	<ul style="list-style-type: none"> Trapezoidal acceleration/deceleration Advanced S-curve acceleration/deceleration 	<ul style="list-style-type: none"> S-curve acceleration/deceleration 	<ul style="list-style-type: none"> Trapezoidal acceleration/deceleration 	<ul style="list-style-type: none"> S-curve acceleration/deceleration 	
Manual control	<ul style="list-style-type: none"> JOG operation JOG operation simultaneous start 	<ul style="list-style-type: none"> Manual pulse generator operation 	<ul style="list-style-type: none"> JOG operation 	<ul style="list-style-type: none"> Manual pulse generator operation Inching operation 	
Function to change the control details	<ul style="list-style-type: none"> Current value change Torque limit value change Acceleration/deceleration time change 	<ul style="list-style-type: none"> Target position change Speed change 	<ul style="list-style-type: none"> Current value change Torque limit value change Acceleration/deceleration time change 	<ul style="list-style-type: none"> Target position change Speed change Override 	
Home position return type	<ul style="list-style-type: none"> Proximity dog type 1 Scale home position signal detection type Count type 2 Data set type 1 Dog cradle type Stopper type 2 Dogless home position signal reference method 	<ul style="list-style-type: none"> Proximity dog type 2 Count type 1 Count type 3 Data set type 2 Stopper type 1 Limit switch combined type 	<ul style="list-style-type: none"> Proximity dog type Scale home position signal detection type Count type 2 Data set type 	<ul style="list-style-type: none"> Count type 1 	
Sub function	<ul style="list-style-type: none"> Forced stop Software stroke limit Amplifier-less operation Optional data monitor ROM operation Error history Safety observation Software security key Limit switch output Driver communication 	<ul style="list-style-type: none"> Hardware stroke limit Absolute position system Unlimited length feed Mark detection M-code output Digital oscilloscope Vision system High-speed reading Cam auto-generation 	<ul style="list-style-type: none"> Forced stop Software stroke limit Amplifier-less operation ^(Note-1) Optional data monitor ^(Note-1) Flash ROM backup Module error collection Safety observation Driver communication ^(Note-1) 	<ul style="list-style-type: none"> Hardware stroke limit Absolute position system Unlimited length feed Mark detection M-code output Digital oscilloscope Cam auto-generation 	

(Note-1): Available only with the QD77MS and LD77MS.

Outline

Motion Controller

Simple Motion

Network

Servo Amplifier

Engineering Environment

SSCNET III/H compatible
MELSEC-Q series Motion controller

Q173DSCPU/Q172DSCPU



Multiple CPU System for High-speed Motion Control



- The Q-series Motion controllers can configure a Multiple CPU system with Programmable controllers.
- Over 100 types of Q series modules are available, which enhances system scalability.
- Up to 96 axes of servo motors can be controlled by using three modules of the Q173DSCPU.
- Position/speed/torque/advanced synchronous controls, etc. are available.
- The safety observation function is available as standard.
- The COGNEX vision system can be connected directly with Ethernet connection.
- The MELSEC-L series I/O modules, analog I/O module, and high-speed counter module can be used when the SSCNETIII/H Head module LJ72MS15 is connected in the system.

[System configuration]

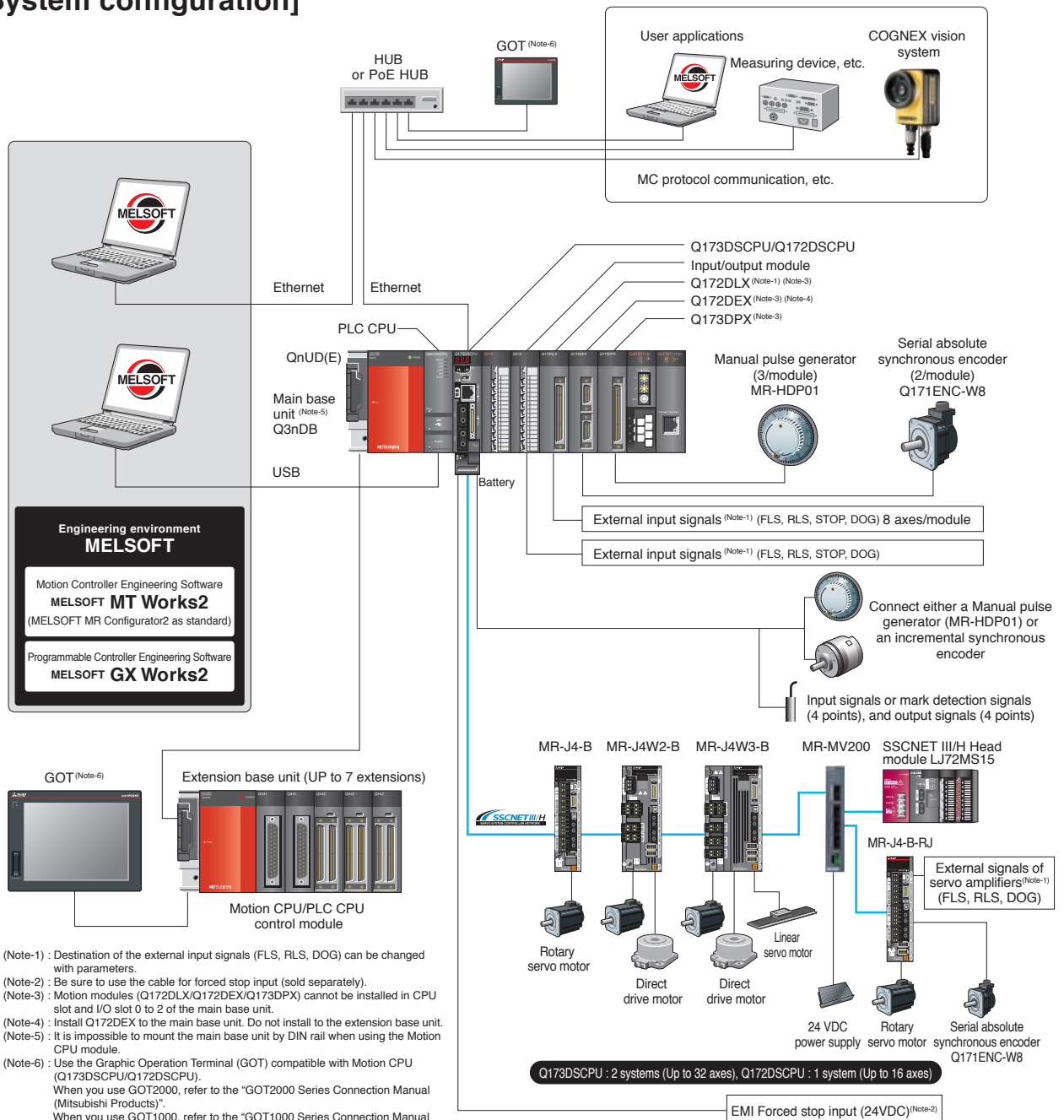

SSCNET III/H compatible
MELSEC-Q series Motion controller

Q170MPCPU/Q170MPCPU-S1

Power Supply, PLC, and Motion Controller All in One



- Up to 16 axes can be controlled.
- Position/speed/torque/advanced synchronous controls, etc. are available.
- Incremental synchronous encoder interface and Mark detection interface are integrated.
- PLC capacity is increased to 60k steps (Q170MPCPU-S1), and up to 7 extension base units can be used.
- STO (Safe torque off) is achieved by combining the servo amplifier
- The COGNEX vision system can be connected directly with Ethernet connection.
- The MELSEC-L series I/O modules, analog I/O module, and high-speed counter module can be used when the SSCNETIII/H Head module LJ72MS15 is connected in the system.

[System configuration]

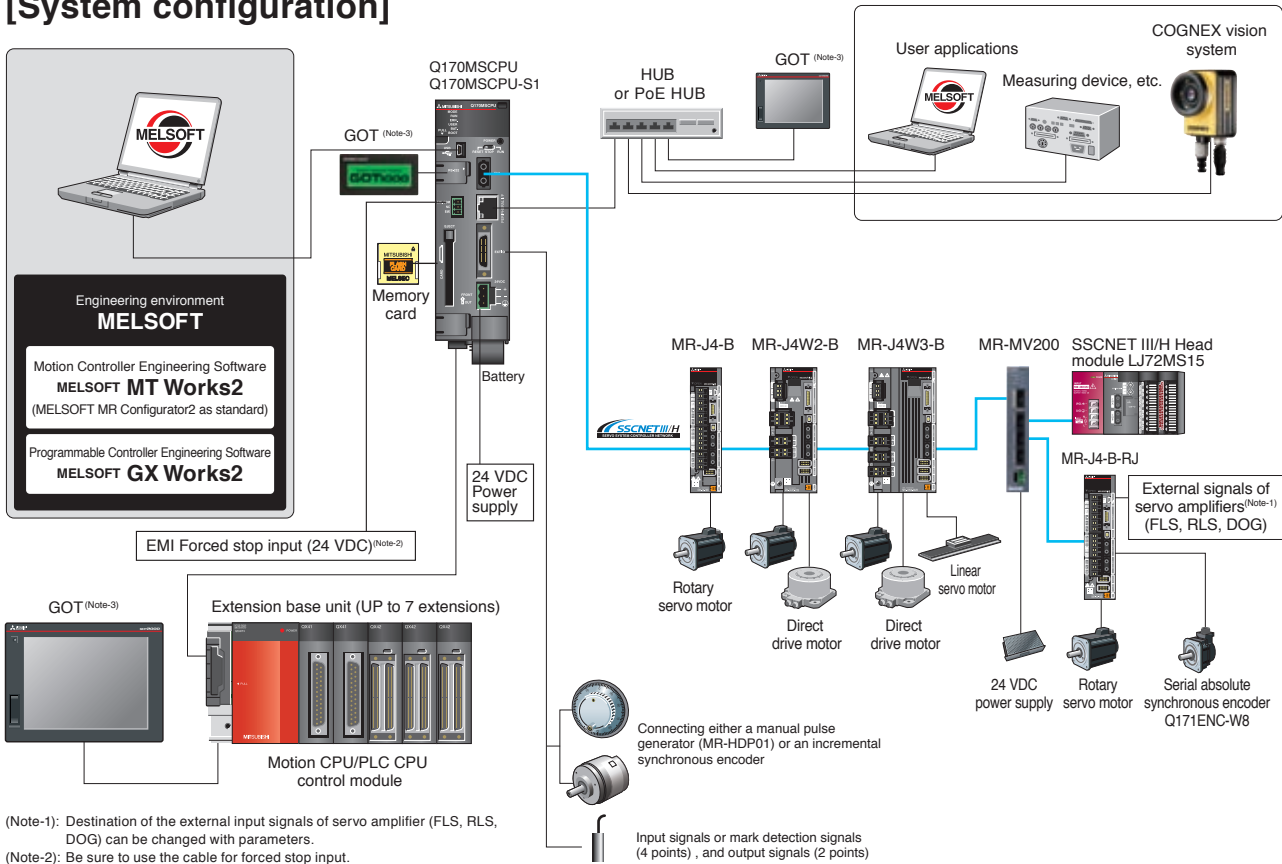

(Note-1): Destination of the external input signals of servo amplifier (FLS, RLS, DOG) can be changed with parameters.
 (Note-2): Be sure to use the cable for forced stop input.
 (Note-3): Use the Graphic Operation Terminal (GOT) compatible with Q170MPCPU(-S1).
 When you use GOT2000, refer to the "GOT2000 Series Connection Manual (Mitsubishi Products)".
 When you use GOT1000, refer to the "GOT1000 Series Connection Manual (Mitsubishi Products)".

Outline

Motion Controller

Simple Motion

Network

Servo Amplifier

Engineering Environment

Features

Reduced wiring, basic performance, Multiple CPU control for all customer needs

Multiple CPU Control by PLC CPU and Motion CPU

Q17nDSCPU

Q170MSCPU

CPU loads are distributed by sharing tasks between the Motion controller and the Programmable controller. Complex servo controls are executed by the Motion controllers, while machine and information control is managed by the Programmable controllers.

By selecting the Motion CPU and PLC CPU according to the application, a flexible system is configured.

The program of Motion CPU is described with the Motion SFC program.

[Multiple CPU High Speed Bus]

Maximum of 14k words are transferred every 0.88ms through the dedicated multiple CPU high speed bus.

The Multiple CPU high speed transmission cycle is synchronized to the Motion control cycle thus optimizing the control system is achieved.

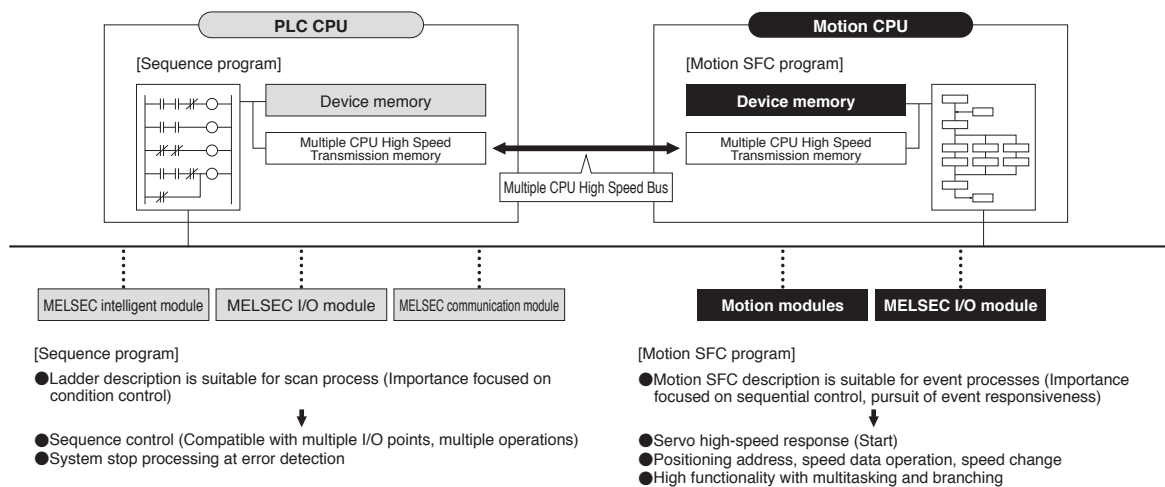

Control Flow

Q17nDSCPU

Q170MSCPU

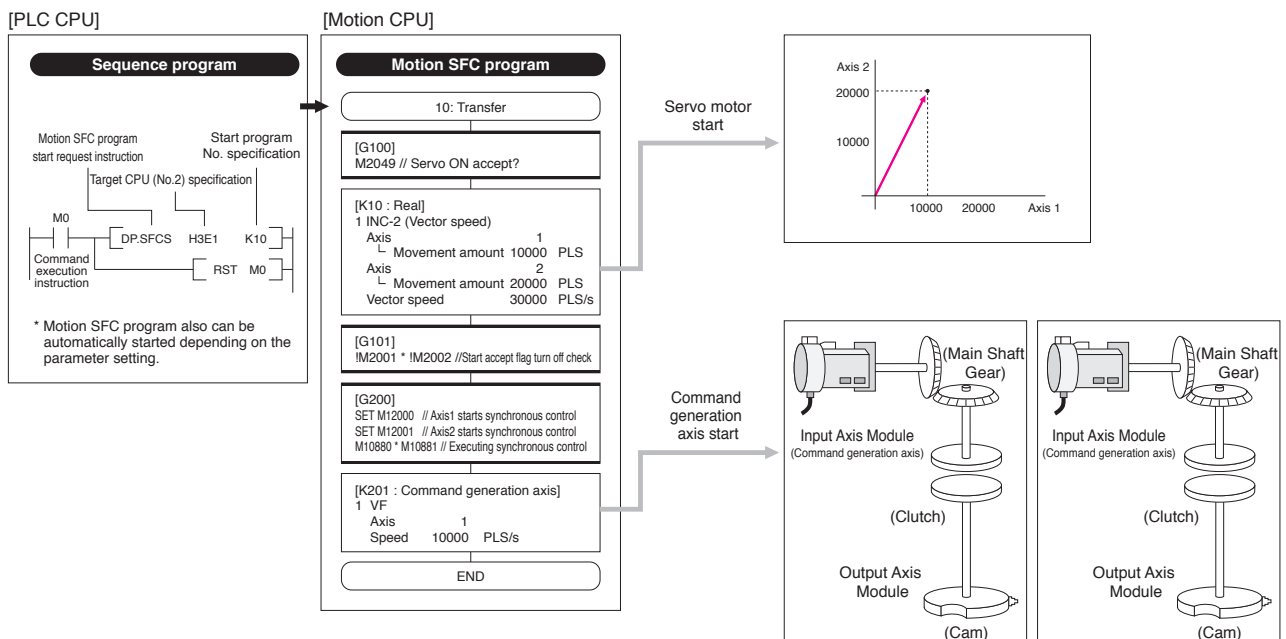

Faster response time enabling shorter tact time

Q17nDSCPU
Q170MPCPU

Operation Cycle of 0.22 ms/4 axes

The Motion operation cycle of 0.22 ms/4 axes is achieved to meet customer needs for a shorter tact time. Even at an operation cycle of 0.44 ms, up to 10 axes are controlled without losing high response.

[Perfect for smooth curve control]

The command data from the Motion controller is transmitted to the servo amplifier every 0.22 ms. Motion Controller with Servo amplifier (MR-J4-B) and servo motor (HG-KR motor: 4,194,304pulse/rev) achieves the shorter operation cycle and smooth motion.

	Operation cycle	
	0.22 ms	0.44 ms
Q173DSCPU	4 axes	10 axes
Q173DCPU	—	6 axes

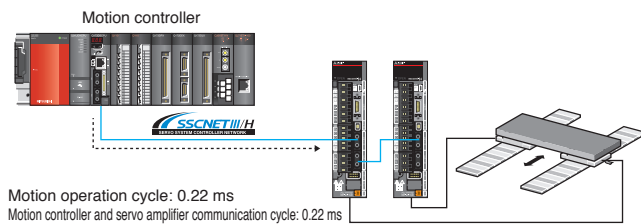

SSCNET III/H Head module greatly contributing to wire reduction

Q17nDSCPU
Q170MPCPU

Reduced Wiring, Space Saving

The SSCNET III/H Head module is used to connect the MELSEC-L series I/O module and intelligent function module to the SSCNET III/H.

Functioning as the Motion controller's remote station, a system can be configured flexibly with the I/O modules and intelligent function modules, the system wiring can be reduced, and space can be saved.

In addition, modules mounted on the SSCNET III/H Head module can be used as a Motion controller input/output using cyclic transmission.

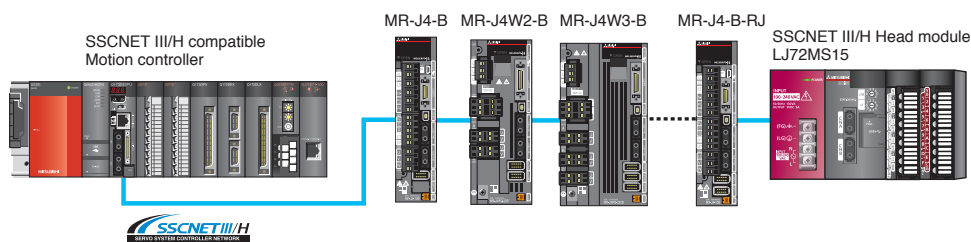

Specifications

- Maximum number of stations: 4 stations
- Maximum I/O points per system
 - Input points 256 bytes
 - Output points 256 bytes
- Maximum I/O points per station
 - Input points 64 bytes
 - Output points 64 bytes

Connectable to various modules such as I/O, analog, and high-speed counter.

Features

Event processing and programming environment have been significantly improved.

Task Operation Examples of Motion SFC Program (SV13/SV22)

Q17nDSCPU

Q170MSCPU

The Motion control program is described in flowchart form using the Motion SFC (Sequential Function Chart) format.

- Motion SFC format program is suitable for the event process and controlling sequential machine operation.
- The entire system operation is easily programmed by using the icons such as **F** (Arithmetic Operation, I/O Control), **G** (Transition Conditional judgment) and **K** (Motion Control) where they are arranged in a sequential process.

Motion SFC description

Flowchart description are easy to read and understand

- The machine operation procedure is visualized in the program by using the flowchart descriptions.
- A process control program can be created easily, and control details can be visualized.

A logical layered structure program

- Operation commands are easily described by creating comments.
- Operation commands are detailed in a step by step format in a layered structure program.

Controlling sequential machine operation using the Motion CPU

- Servo control, I/O control, and operation commands can be combined in the Motion SFC program.
- Motion SFC program can execute servo control by itself, eliminating the need of creating the sequence program for servo control.

Enhanced operation functions

- Commands are able to be described with arithmetic and logic operation expressions.
- Compatible with 64-bit floating-point operations.
- Arithmetic functions include trigonometric functions, square root, natural logarithm, etc.
- The conditional branch (IF ELSE IEND), selective branch (SELECT CASE SEND) and repetition instruction (FOR NEXT) can be described.

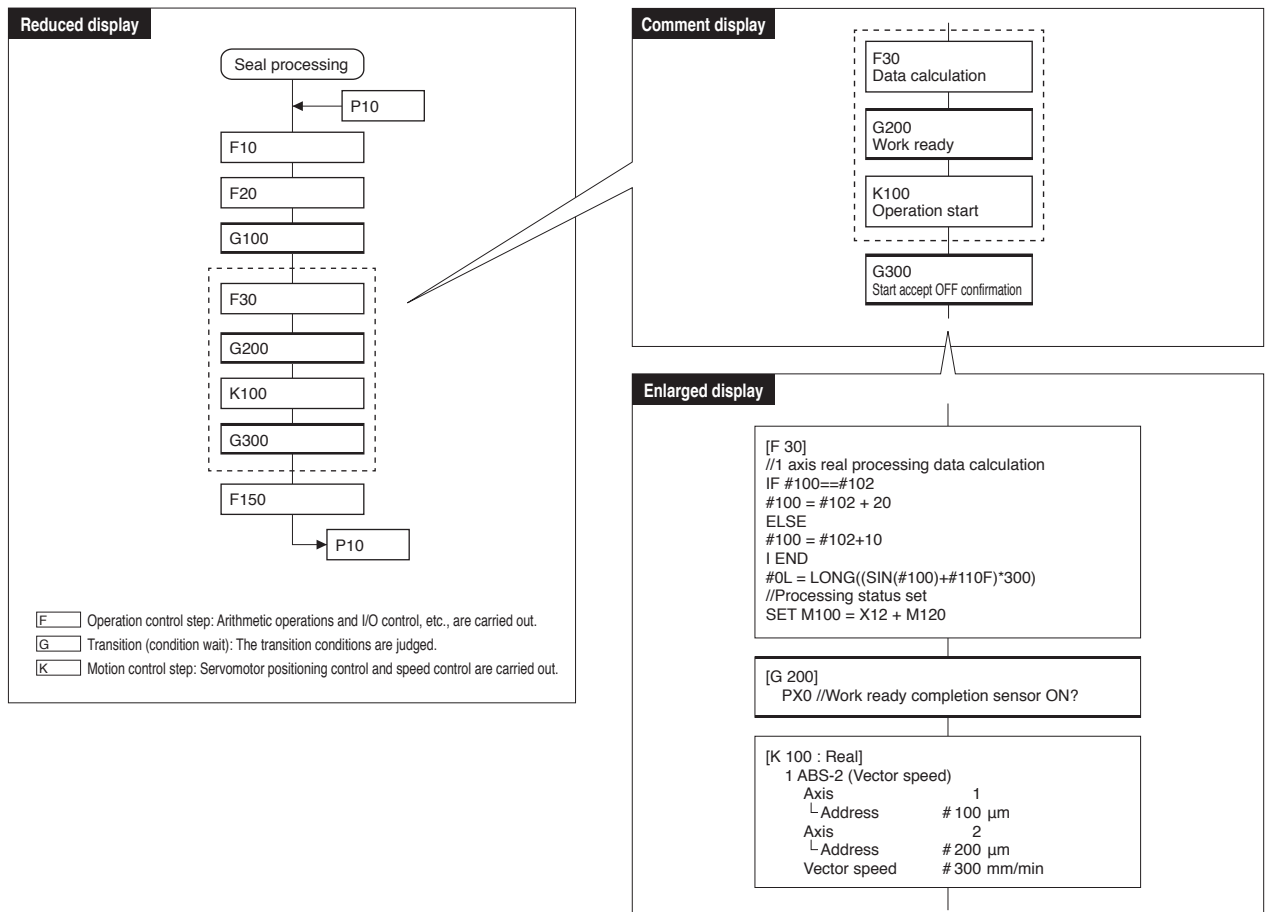

Motion SFC scanning method

While the sequence program runs using “Scan execution method” where all of the steps are scanned at all times, the Motion SFC program runs using “STEP execution method” where the steps are scanned following the “SHIFT” instruction, which enables to reduce operation process for high-speed processing and high-response control.

Scanning all the steps in the sequence programs

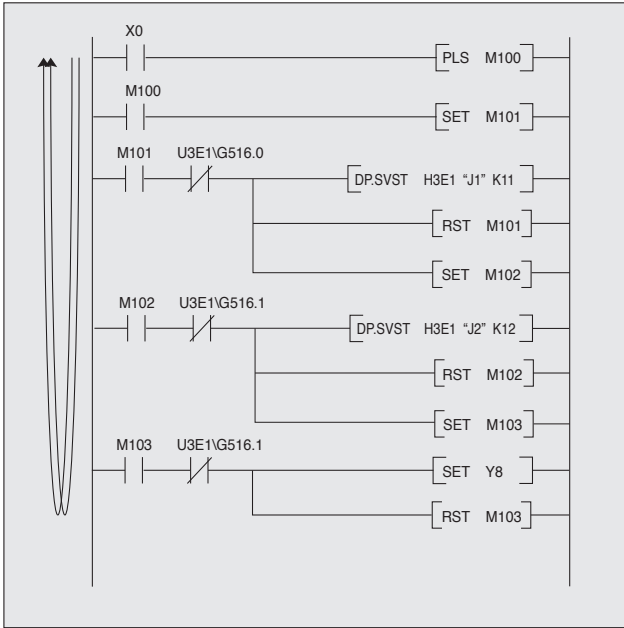

Scanning only active steps following the transition conditions in Motion SFC program.

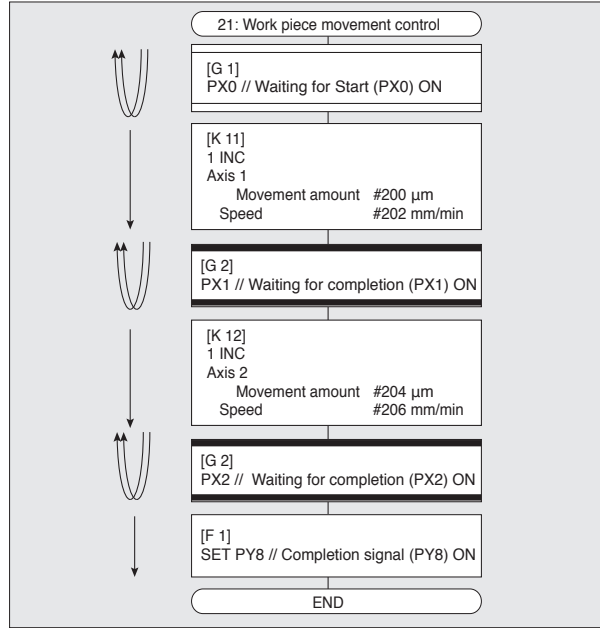

Outline

Motion Controller

Simple Motion

Network

Servo Amplifier

Engineering Environment

Operating System Software (SV22 is pre-installed before shipment.)

Q17nDSCPU

Q170MSCPU

“SV13” for conveyor assembly and “SV22” where the synchronous control is available are provided as the operating system software of Motion controllers. For the synchronous control, you can choose from either “Advanced synchronous control” or the one that uses the mechanical system program. SV22 is pre-installed before shipment.

[Automatic machinery use SV22]

[Conveyor assembly use SV13]

- Electronic component assembly
- Inserter
- Feeder
- Molder
- Conveying equipment
- Loader and Unloader
- Paint applicator
- Bonding machine
- Chip mounting
- X-Y table
- Wafer slicer
- Circular interpolation
- Constant-speed control
- Fixed-pitch feed
- Speed control with fixed position stop
- Speed switching (1 to 4 axes)
- Speed/position switching control
- Linear interpolation control (1 to 4 axes)
- Teaching
- Speed-torque control

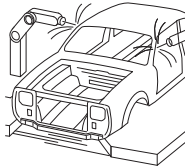

Motion SFC Program

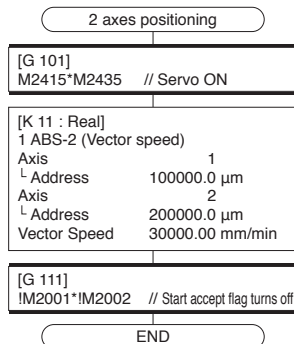

- Press feeder
- Food processing
- Food packaging
- Winding machine
- Spinning machine
- Textile machine
- Knitter
- Printing machine
- Book binder
- Tire molder
- Paper-making machine
- Synchronous control
- Electronic shaft
- Electronic clutch
- Electronic cam
- Draw control
- Speed-torque control

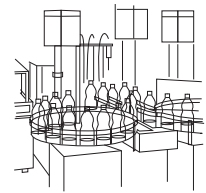

Advanced Synchronous Control

Synchronous control can be easily executed just by setting the parameters.



Mechanical System Program

Synchronous control can be achieved just by drag&drop the mechanical modules on screen.

Features

Advanced Synchronous Control

Q17nDSCPU

Q170MSCPU

Started/Stopped on axis-by-axis basis, “Synchronous control” can be executed easily using software instead of controlling mechanically with physical gears, shafts, speed change gears or cam, etc. Additionally, a cam is easily created with the cam auto-generation function. Axes in synchronous control and positioning control can be used together in the program. There are two types of synchronous control, “Advanced synchronous control” and the one using the mechanical system program, and you can select either of them.

Control flow

[PLC CPU]

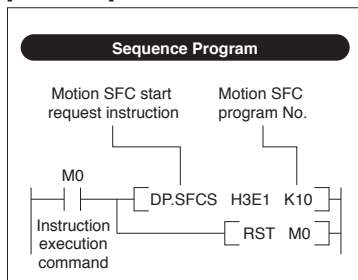

(Note) Motion SFC program can be also automatically started depending on parameter settings.

[Motion CPU]

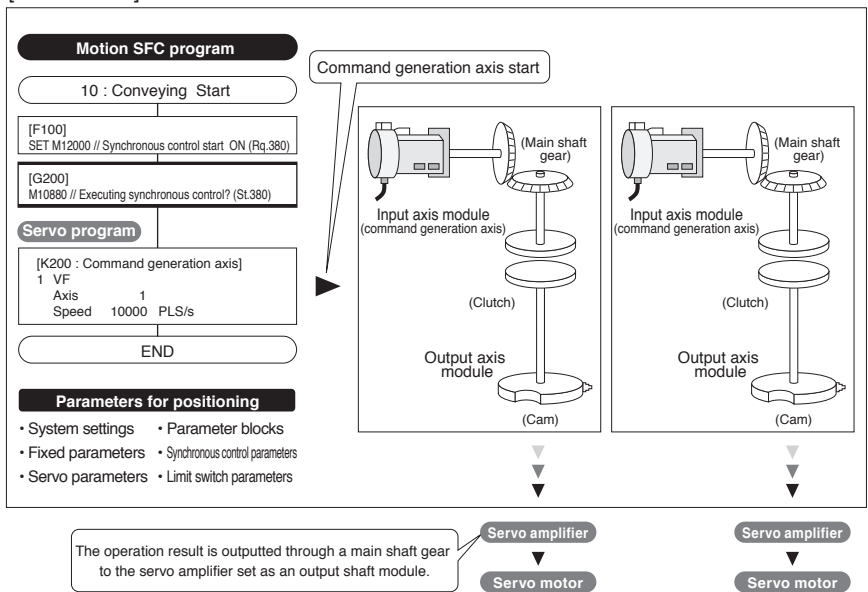

The operation result is outputted through a main shaft gear to the servo amplifier set as an output shaft module.

Synchronous control parameters

- The synchronous control is easily executed just by setting parameters.
- The movement amount of the main shaft can be transmitted to output axes via the clutch.
- “Command generation axis” is not considered as a control axis; therefore the output axes can be set using all of the available control axes.

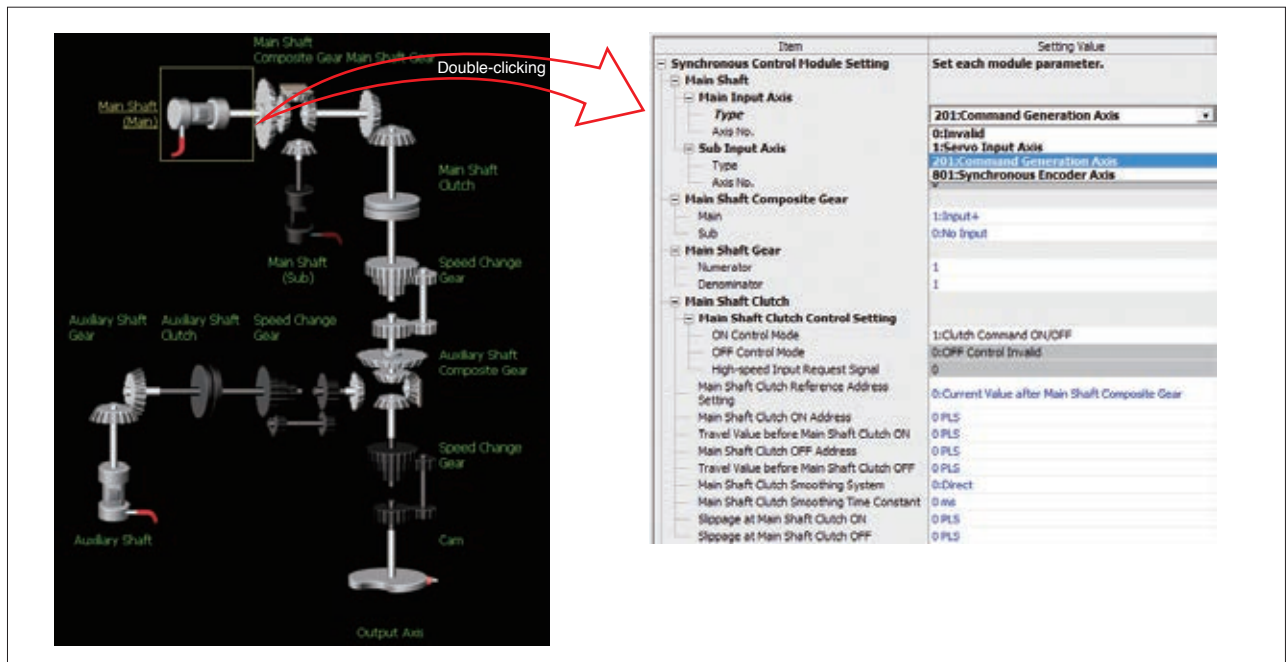

Electronic cam

A wide variety of cam patterns can be easily created.

[Cam Data Creation Screen]

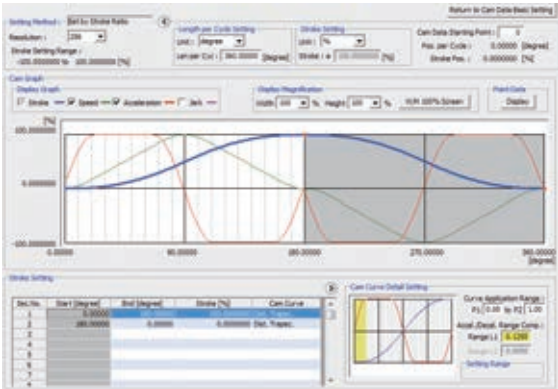

- Cam data has been created more freely and flexibly.
- To change the waveform, simply drag and drop it. The graph automatically change according to the pointer's movement.
- Stroke, speed, acceleration, and jump of speed can be set while checking the change of the graph.
- Cam data can be imported and exported in CSV format.

[Cam Data List]

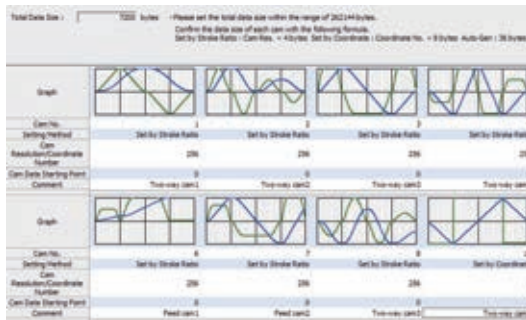

- The created cam data are easily viewed as thumbnails.
- The screen for cam data creation will open by double-clicking the cam data to be edited.

Cam auto-generation

The cam auto-generation function can automatically create cam data which is synchronized to the conveyor speed when the rotary cutter cuts the material. The function is executed just by setting a sheet length, cam resolution, etc.

[User-created GOT screen example]

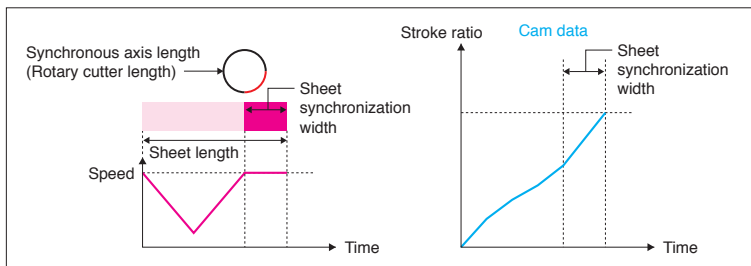
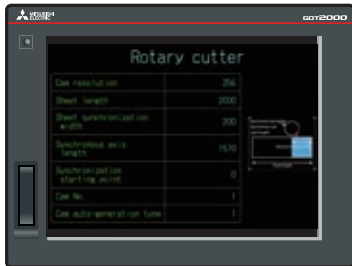

Mechanical System Program

Q17nDCPU
Q170MSCPU

The synchronous control using the conventional mechanical system program is also possible.

Refined synchronous control with simple settings

Synchronous control can be easily achieved with a graphical program where the mechanical modules such as a virtual main shafts, gears, clutches and cam are programmed on screen.

- Select and arrange the virtual modules on screen using a mouse, and set the parameters to be used.
- You can easily understand the outline of the synchronous control just by looking at the mechanical system program.
- Synchronous control monitoring is available on the mechanical system program.

[Easy programming with a mouse]



Programming screen using mechanical system program

Features

Safety System

Q17nDSCPU

The safety system is compliant with “EN ISO13849-1:2008 Category 3 PLd” and “EN62061 SIL CL2” (these standards are harmonized with European Machine Directives). Functional safety (STO, SS1, SS2, SOS, SSM, SBC, SLS) according to IEC61800-5-2 are available as standard, as well as the safety signal comparison function, which confirms the status of the input/output signals by the Motion CPU and the PLC CPU. The operating conditions for these functions are freely programmed by using the PLC CPU and Motion CPU ladder circuits.

Speed monitoring function

The motor speed is monitored not to exceed the "Safety Speed" by the Motion CPU and the PLC CPU.

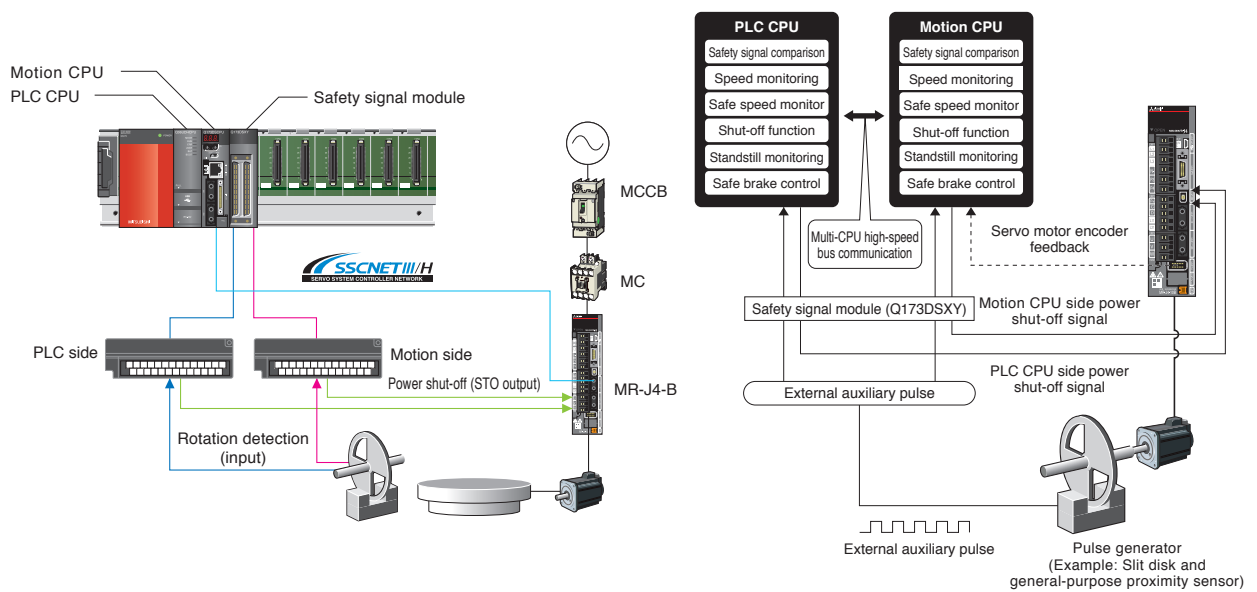

Safety signal comparison function

The safety input signals are monitored using the Motion CPU, PLC CPU and safety signal module.

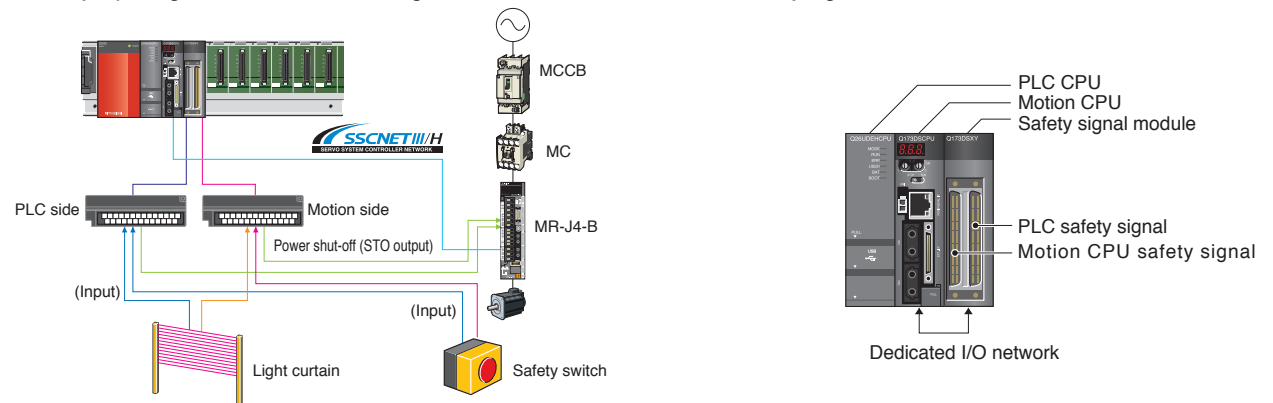

PLC CPU	QnUD(E)(H)CPU (Note-1)
Motion CPU	Q173DSCPU/Q172DSCPU
Safety signal module	Q173DSXY (up to 3 modules can be installed) (Note-2)
Number of input points	Up to 60 points × 2 systems
Number of output points	Up to 36 points × 2 systems

(Note-1): The safety system is certified by Certification Body only for the combination of Q173DSXY and "QnUD(E)(H)CPU"

(Note-2): All output signal points at the 2nd and 3rd modules can be used as user safety signals.

	No. of points	Signal description
Input	20	User safety signals
Output	1	Power shut-off signal (Note-3)
	11	User safety signals

(Note-3): Power shut-off signal turns: ON when safety signal comparison function status is normal. OFF when error is detected.

Safety Communication via SSCNET III/H

Functional safety (STO, SS1, SSM, SBC, SLS) according to IEC 61800-5-2 can be achieved with a combination of MR-J4-B-RJ servo amplifier and MR-D30 functional safety unit. The safety observation function can be easily started up by setting parameters for MR-D30.

The sequence program for the functional safety, created by the Motion controller, is not required when using MR-D30 functional safety unit.

The servo amplifier with software version B3 or later supports the safety observation function.

[The safety signal comparison executed by MR-J4-B-RJ with MR-D30]

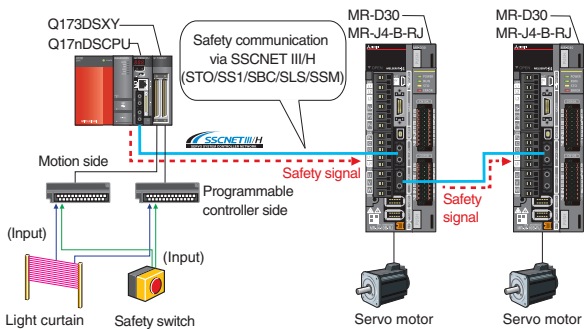

The wiring for power shutoff (STO) between the outputs on controller side and the servo amplifier is no longer needed.

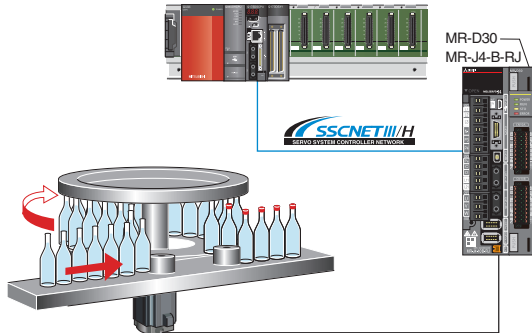

Safely-limited speed (SLS) is available without an external pulse generator.

- Outline
- Motion Controller
- Simple Motion
- Network
- Servo Amplifier
- Engineering Environment

Safety Category

Q17nDSCPU

ISO13849-1 Safety categories

“Safety categories” are indicators used to determine specific safety measures based on risk assessment results.

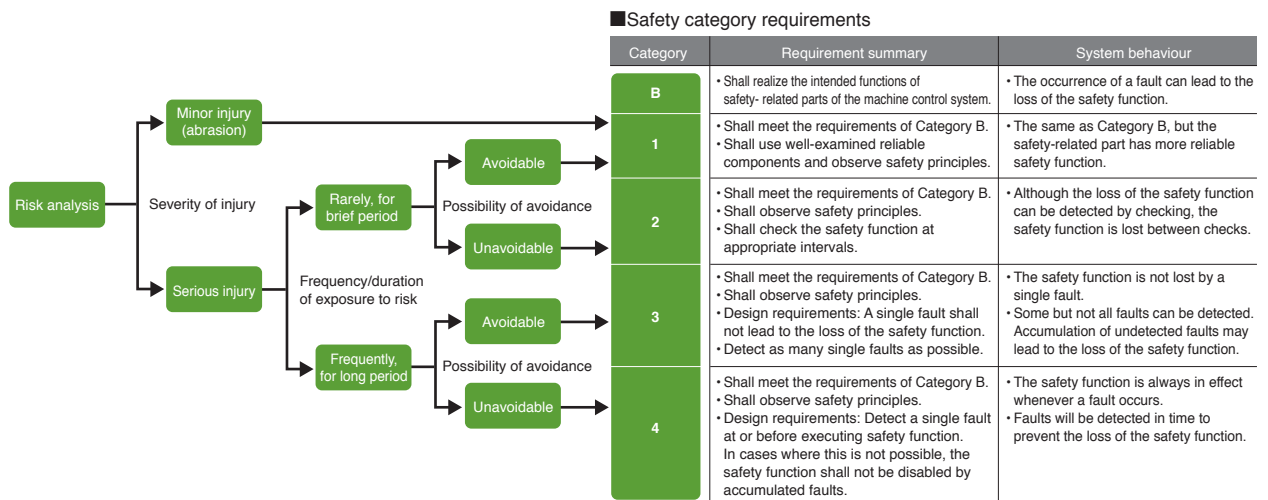

ISO13849-1:2006 Performance level

Performance levels for safety-related parts of control systems have been revised in ISO13849-1:2006.

Based on the original safety categories, frequency of a dangerous failure occurrence (the safety function does not work when needed), rate of a failure detection by diagnostics, etc. were added to evaluate comprehensively. The evaluation result is classified into five levels from “a” to “e” by the performance level (PL).

● Like the safety categories, the risk is evaluated from a perspective of “S: Severity of injury,” “F: Frequency or duration of exposure to risk,” and “P: Possibility of avoidance.”

■ Risk graph in ISO13849-1:2006 and PLr for functional safety

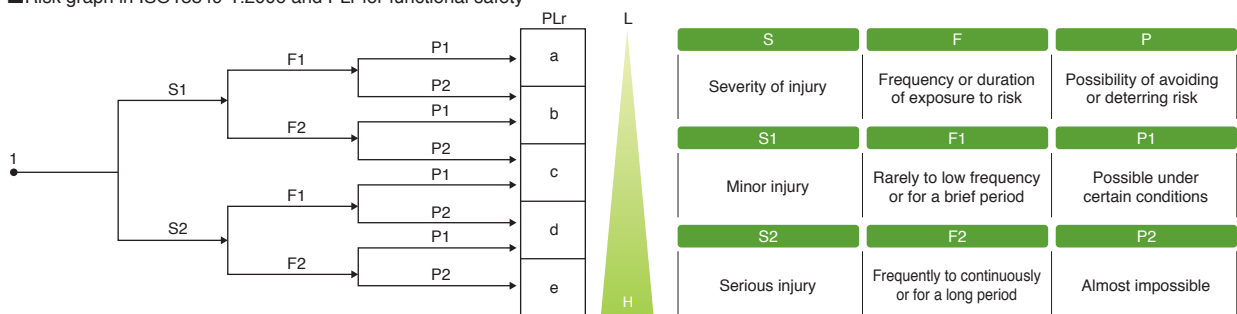

Safety Category IEC/EN 61800-5-2

These functions are defined as “power drive system electric safety function” in IEC/EN61800-5-2. The functions supported by the Motion controller are listed on the right.

Item (IEC/EN 61800-5-2:2007)	Description
STO	Safe torque off
SS1	Safe stop 1
SS2	Safe stop 2
SOS	Safe operating stop
SLS	Safely-limited speed
SBC	Safe break control
SSM	Safe speed monitor

Speed-torque Control (Tightening & Press-fit Control)

Tightening & Press-fit control Patent pending

Q17nDSCPU

Q170MSCPU

Torque control and tightening & press-fit control are available in addition to position control and speed control. Switching the control mode (position control→torque control→position control, as shown on the right) is also possible with the Motion dedicated device. The torque control has two modes: "Torque control" which starts after stopping the movement once to ensure safety, and "Tightening & press-fit control" which starts during the movement. The current position is controlled during both torque control and speed control. Therefore positioning based on the absolute position coordinates is possible even after switching back to position control.

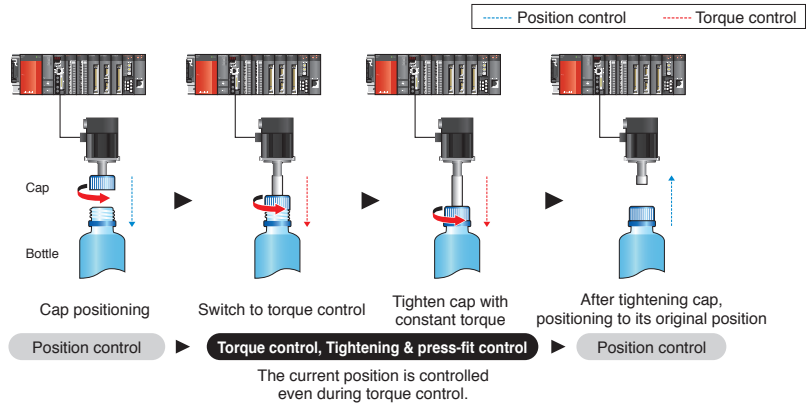

Mark Detection Function

Q17nDSCPU

Q170MSCPU

The actual position of the servo motor can be obtained based on the inputs from the sensor that detects the registration marks printed on the high-speed moving film. By compensating the cutter axis position errors based on those inputs from the sensor, the film can be cut at the set position.

[Position compensation during registration mark detection]

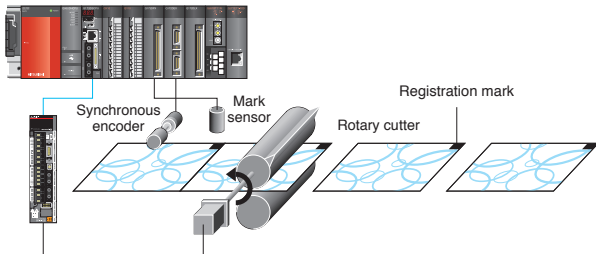

Advanced S-curve Acceleration/Deceleration

Q17nDSCPU

Q170MSCPU

The interval ratio between the following two is adjustable: the interval where acceleration rate changes smoothly (Sin wave interval), and the interval where the maximum acceleration rate is maintained (constant acceleration interval). The total acceleration time can be reduced without losing smoothness and high response.

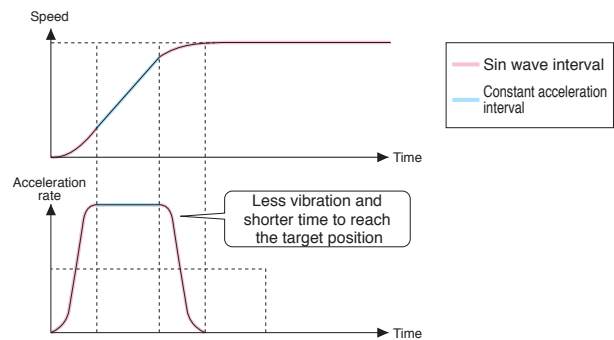

Software Security Key Function

Q17nDSCPU

Q170MSCPU

User data is protected by setting a software security key to the project and the operating system software "MELSOFT MT Works2". Access of the the personal computers and Motion CPU modules to the projects is limited.

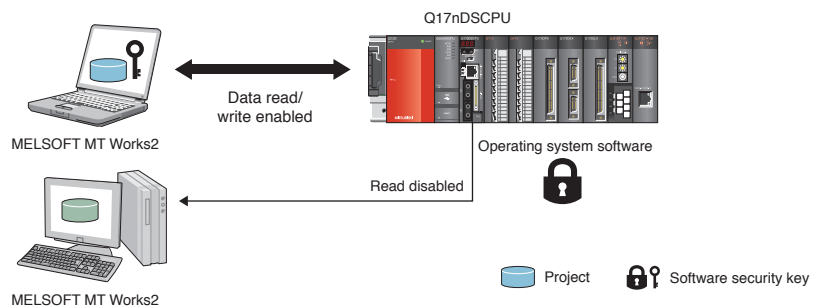

Outline

Motion Controller

Simple Motion

Network

Servo Amplifier

Engineering Environment

Features

Optical hub unit

Q17nDSCPU

Q170MSCPU

The MR-MV200 can branch a single SSCNET III/H network line in three separate directions. This enables distribution of the high-performance MELSERVO-J4 series servo amplifiers with flexible wiring arrangement.

- The SSCNET connect/disconnect function of the Motion controller allows you to power off only the desired servo amplifiers.
- This unit is introduced just by making some changes in wiring without making any new settings.
- Longer-distance wiring becomes available by using this optical hub unit.

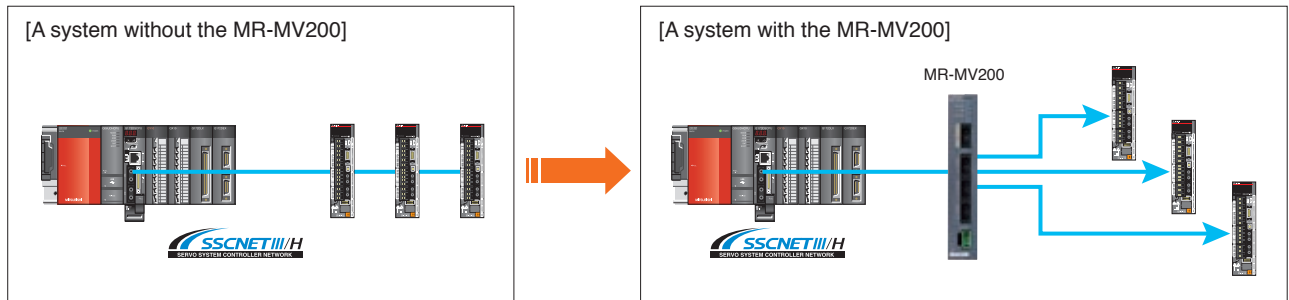

[System configuration example]

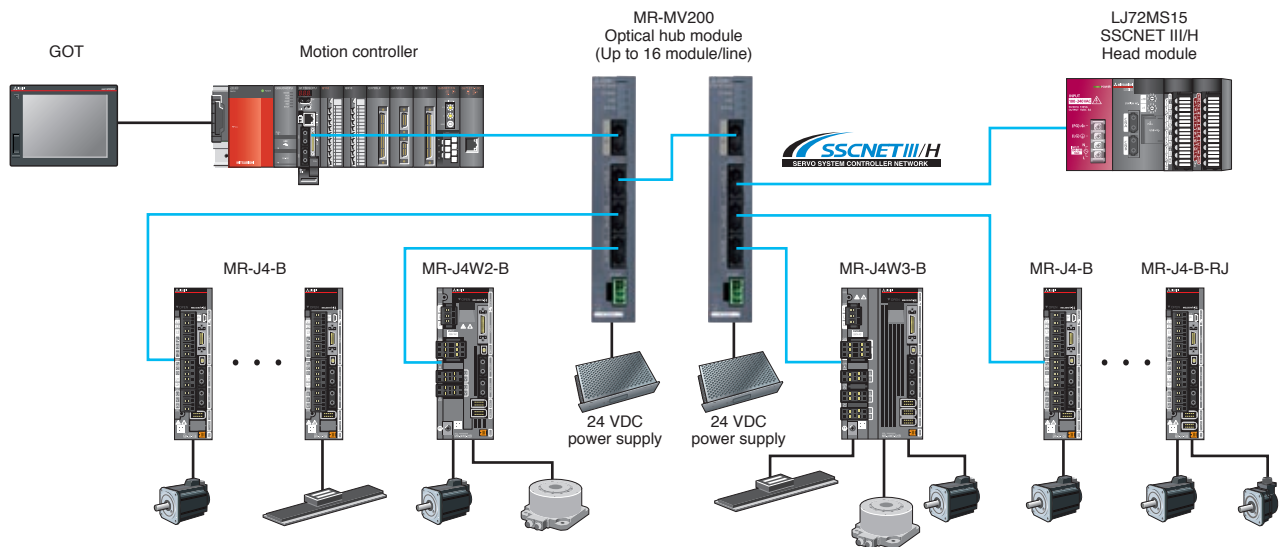

Note): MELSOFT MT Works2 supports a system using the optical hub unit without any restriction.
 Note): Be sure to confirm that "SSCNET III/H" is selected in the system setting when introducing the optical hub unit.
 Note): The MR-MV200 cannot be connected to a "J3 compatible mode" system. Make sure to use it in a "J4 mode" system.

Various Basic Functions

Q17nDSCPU

Q170MSCPU

Servo external input signals

The servo external input signals (FLS, RLS, DOG) can be controlled via the bit device or general-purpose input signal in addition to via the servo external signals interface module (Q172DLX) and via the servo amplifier. The logic and the validity of these signals are set individually, which makes these signals more flexible to use.

Internal Input signal (4-point)

The Motion CPU has the internal input signal I/F (max. 4 points) which can be used for the general-purpose input signal or mark detection input signal, etc.

ROM operation function

Systems can be operated with the programs and parameters stored in the built-in FLASH ROM of the Motion CPU. If the system does not require an absolute position system or latch device, operation can be carried out without a battery.

Home position return methods

A wide variety of functions, including thirteen home position return methods, the retry function and the shift function etc. are available to establish the home position used as the machine reference point. Select a home position return method according to the machine type.

Target position change function

The target position can be changed during positioning operation. When compensating the position fluctuation using the data from the vision sensor, etc., the positioning operation to the final compensated position is completed without restarting the positioning.

Optional data monitor function

Various servo amplifier control data can be monitored by setting the data type or monitor data storage device to the MELSOFT MT Works2 system settings. For the Motion controller with the MR-J4-B, up to six types of data, including power consumption and total power consumption, can be monitored.

Servo parameter change function

Servo parameters can be individually changed during control operation through the Motion SFC program and etc., without connecting to a personal computer.

Phase compensation

In synchronous control with a synchronous encoder, the phase compensation function is used to make up the delay time caused by a communication delay in the synchronous encoder data, etc.

Operation control program

Binary operation, bit operation, type conversion and trigonometric in the Motion SFC comes as standard functions. In addition, more functions have been newly available such as the command for the scaling function that is suitable for calculating coordinate conversions, the cam data reading/writing, and the synchronous control dedicated instruction for cam auto generation. Conditional branching at an operation control step is also available.

PERIPHERAL I/F (Ethernet)

The Motion CPU has a built-in PERIPHERAL I/F which is designed to be connected to various devices such as the graphic operation terminal, COGNEX vision system with Ethernet etc.

4 million pulse synchronous encoder

The "Q171ENC-W8" 4 million (22-bit) pulse synchronous encoder, compatible as standard, greatly improves the synchronous operation accuracy. (16 times higher resolution than conventional model.) High-accuracy control is achieved when used with MR-J4-B (adapting 4 million (22-bit) pulses resolution motors as standard).

Limit switch output function

Signals can be set to turn ON/OFF within the setting range of the watch data such as the real current value, motor rotation speed or motor current during operation.

Speed control with fixed position stop

The servo motor is set to rotate at the specified speed and then stops at the specified position when turning ON the command of Speed control with fixed position stop. Both the speed and the duration of acceleration/deceleration can be changed to any value during operation, which is suitable for a spinner, etc.

Digital oscilloscope function

With the digital oscilloscope function of MELSOFT MT Works2, data collection which is synchronized to the operation cycle and waveform display are available just by following the assistant function. Data of up to 16CH words or bits can be sampled, and of which 8CH words or bits can be displayed in real time.

Torque limit value change

The torque limit value during positioning or JOG operation is changed easily with the Motion dedicated instruction CHGT. By using the individual change request of torque limit value "CHGT2", the torque limit of driving direction and regeneration direction is possible to set individually.

Servo amplifier control mode switching function

Control mode switch commands of the gain switching function, PI-PID control and control loop (fully closed, semi-closed) can be executed to the servo amplifier.

Electronic cam control

The electronic cam control is available with cam data created on MELSOFT MT Works2. Cam control for a degree axis and indirect designation of the number of pulses per cam axis rotation are possible now with new Motion CPU.

Multiple CPU synchronous control

Up to 96 axes can be synchronized by use of three Motion controllers. (available only with Q173DSCPU/Q172DSCPU)

Comprehensibly supporting Motion controller design and maintenance

Programming

User-friendly functions for program development

- Graphical Motion SFC program, mechanical system program
- Label, device comment, cross reference
- Programming with axis label (name)
- Instruction wizard and instruction help eliminate need to refer to manuals.

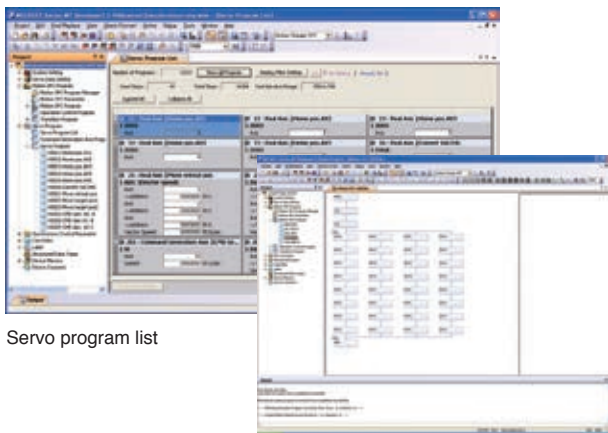

Servo program list

Motion SFC program

Easily diverting the existing program

- Easily divert the existing SFC program from the original project to the new project just by drag&drop.
- You can add the program comments to the project tree for easy identification of programs.

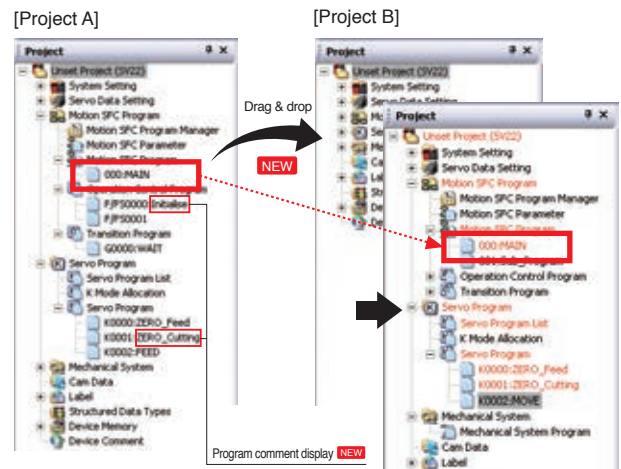

System Design

- You can easily set servo amplifiers and various modules with a graphical system setting screen.
- The one-point help is available to set parameters without manuals.
- The complicated electric gear settings can be completed just by specifying the mechanical configuration (reduction ratio, ball screw pitch, etc.).

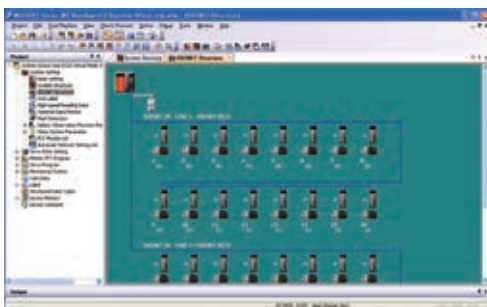

SSCNET structure



Servo data



Electronic gear setting

Setup and Adjustment

Monitor function

Easy confirmation of the Motion controller operation status with the various monitoring functions.

- Motion SFC program monitor
- Mechanical program monitor
- Current value monitor, positioning monitor, scroll monitor, error history monitor
- Device monitor



Monitor

Digital oscilloscope function

Operation check and troubleshooting are powerfully supported with data collection and wave displays which are synchronized to the Motion operation cycle.

- The assistant function explains all work steps.
- Set often-viewed data easily with the purpose-based probe setting.
- Sample 16CH word and 16CH bit data. Of which, 8CH words and 8CH bits can be displayed in real time.

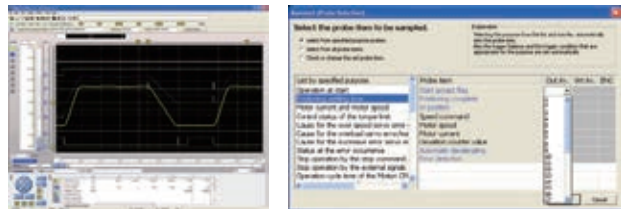

Digital oscilloscope

Various test operation functions

- Basic startup can be confirmed without programming with the test mode.
- Simulator function executes the debugging of the Motion SFC program and the advanced synchronous control on desktop without using an actual machine.
- Step execution and brake point setting are possible with the Motion SFC program debug function.

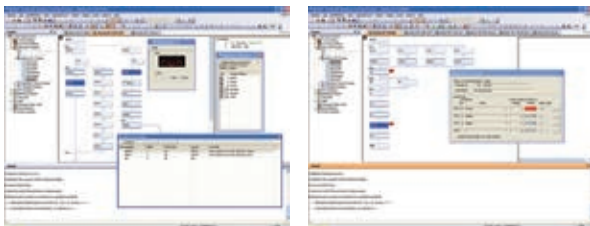

Simulator

Test

Coordinated with MELSOFT MR Configurator2

- Adjust servo parameters with MELSOFT MR Configurator2, the software created with Mitsubishi servo know-how.
- Adjust multiple axes with a personal computer connected to the controller.
- MELSOFT MR Configurator2 is included in MELSOFT MT Works2.

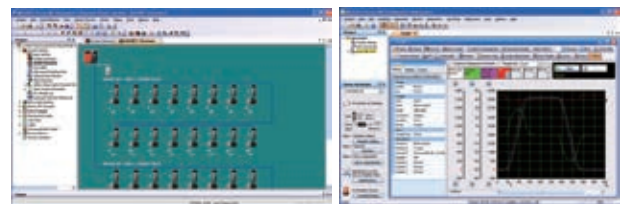

Graph

A Variety of Security Options

Controlling access to project data

- Specify the users who can access to the project to ensure the security.
- Prevent inadvertent editing of the created project data by setting access limits to each registered user.

Protecting Motion SFC programs

- Display/Not display of program contents can be set for each Motion SFC program by password. This can prevent a program data in project from stealing.

Controlling access to Motion CPU

- A software security key set to the Motion CPU and personal computer prevents the Motion CPU from unauthorized access.

Specifications

Control specification

Item	Specifications			
	Q173DSCPU	Q172DSCPU	Q170MSCPU-S1	Q170MSCPU
Number of control axes	Up to 32 axes (16 axes/system)		Up to 16 axes	
Operation cycle (Operation cycle setting)	0.22 ms, 0.44 ms, 0.88 ms, 1.77 ms, 3.55 ms, 7.11 ms			
Interpolation function	Linear interpolation (Up to 4 axes), Circular interpolation (2 axes), Helical interpolation (3 axes)			
Control modes	PTP (Point to Point) control, Speed control, Speed-position switching control, Fixed-pitch feed control, Constant speed control, Position follow-up control, Speed control with fixed position stop, Speed switching control, High-speed oscillation control, Cam control (SV22), Speed-torque control, Synchronous control (SV22(Advanced synchronous control method/Virtual mode switching method))			
Acceleration/deceleration control	Trapezoidal acceleration/deceleration, S-curve acceleration/deceleration, Advanced S-curve acceleration/deceleration			
Compensation function	Backlash compensation, Electronic gear, Phase compensation (SV22)			
Programming language	Motion SFC, Dedicated instruction, Mechanical support language (SV22)			
Servo program capacity	16k steps			
Number of positioning points	3200 points (Positioning data can be set indirectly)			
Peripheral interface	Motion CPU (area)	PERIPHERAL I/F		
	PLC CPU (area)	USB, RS-232, Ethernet		USB, RS-232
Home position return function	Proximity dog type (2 types), Count type (3 types), Data set type (2 types), Dog cradle type, Stopper type (2 types), Limit switch combined type, Scale home position signal detection type, Dogless home position signal reference type (Home position return re-try function provided, home position shift function provided)			
JOG operation function	Provided			
Manual pulse generator operation function	Possible to connect 3 modules (Q173DPX use) Possible to connect 1 module (Internal I/F use) ^(Note-5)			
Speed-torque control	Speed control without positioning loops, Torque control, Tightening & press-fit control			
Multiple CPU synchronous control	Up to 96 axes (by use of three modules of Q173DSCPU)		-	
Synchronous encoder operation function	12 modules connectable (SV22) (via Q173DPX+Q172DEX+ internal I/F+ device ^(Note-6) + servo amplifier ^(Note-6))		12 modules connectable (SV22) (via Q173DPX+ internal I/F+ device ^(Note-6) + servo amplifier ^(Note-6))	
M-code function	M-code output function provided, M-code completion wait function provided			
Limit switch output function	Number of output points: 64 points (Advanced synchronous control method), 32 points (Virtual mode switching method (SV13)) Watch data: Motion control data, Word device			
ROM operation function	Provided			
External input signal	Q172DLX (FLS, RLS, STOP, DOG) , External input signals (FLS, RLS, DOG) of servo amplifier, Internal I/F(DI), Bit device			
High-speed reading function ^(Note-6)	Available (Via built-in interface in Motion CPU, input module, tracking of Q172DEX/Q173DPX)		Available (Via built-in interface in Motion CPU, input module, tracking of Q173DPX)	
Mark detection function	Mark detection signal	Continuous Detection mode, Specified Number of Detections mode, Ring Buffer mode		
	Mark detection setting	4 points (Via Internal I/F), Bit device, Q172DLX (DOG)		
Torque limit value change function	32			
Torque limit value change function	Positive direction torque limit value, Negative direction torque limit value			
Target position change function	Provided			
Servo parameter change function	Provided			
Servo amplifier control mode switching function	Gain switching function, PI-PID control, Control loop changing (semi closed loop control, fully closed loop control)			
Optional data monitor function	Up to 6 data/axis (MR-J4-B with SSCNET III/H use)			
Forced stop	Motion controller forced stop (EMI terminal, System setting), Forced stop terminal of servo amplifier			
Number of input/output points	Total of 256 points (Internal I/F (4 input points) + I/O module+ Intelligent function module)		Total of 256 points (Internal I/F (4 input points + 2 output points) + I/O module+ Intelligent function module)	
Clock function	Provided			
Security function	Password registration, Password for every Motion SFC program, Software security key function			
All clear function	Delete all user data in Motion CPU			
Remote operation	Remote RUN/STOP, Remote latch clear			
Digital oscilloscope function	Bit data: 16 channels, Word data: 16 channels ^(Note-4)			
Driver communication function	Provided			
Amplifier-less operation function	Provided			
Absolute position system	Made compatible by setting battery to servo amplifier. (Possible to select the absolute data method or incremental method for each axis)			
Number of SSCNETIII/H systems ^(Note-1)	2 systems		1 system	1 system
Number of Motion modules	Q172DLX	4 modules usable		Q172DLX 2 modules usable
	Q172DEX	6 modules usable ^(Note-2)		Q172DEX 6 modules usable ^(Note-2)
	Q173DPX	4 modules usable ^(Note-3)		Q173DPX 4 modules usable ^(Note-3)

(Note-1): The SSCNETIII compatible servo amplifier can be used, but the SSCNET compatible servo amplifier cannot be used.

(Note-2): Q172DEX cannot be used in SV13.

(Note-3): This is the case of using an incremental synchronous encoder (SV22 used). When using a manual pulse generator, only one module are allowed to use.

(Note-4): 8CH word data and 8CH bit data can be displayed in real time.

(Note-5): The Q173DPX and internal interface can not be used simultaneously.

(Note-6): Advanced synchronous control only.

■ Motion SFC performance specification

Item		Specifications			
		Q173DSCPU	Q172DSCPU	Q170MSCPU-S1	Q170MSCPU
Motion SFC program capacity	Code total (Motion SFC chart + Operation control + Transition)	652k bytes			
	Text total (Operation control + Transition)	668k bytes			
Motion SFC program	Number of Motion SFC programs	256 (No.0 to 255)			
	Motion SFC chart size/program	Up to 64k bytes (Included Motion SFC chart comments)			
	Number of Motion SFC steps/program	Up to 4094 steps			
	Number of selective branches/branch	255			
	Number of parallel branches/branch	255			
	Parallel branch nesting	Up to 4 levels			
Operation control program (F/FS) / Transition program (G)	Number of operation control programs	4096 with F (Once execution type) and FS (Scan execution type) combined (F/FS0 to F/FS4095)			
	Number of transition programs	4096 (G0 to G4095)			
	Code size/program	Up to approx. 64k bytes (32766 steps)			
	Number of blocks(line)/program	Up to 8192 blocks (In the case of 4 steps (min)/block)			
	Number of characters/block	Up to 128 (Comment included)			
	Number of operand/block	Up to 64 (Operand: Constants, Word devices, Bit devices)			
	() nesting/block	Up to 32 levels			
	Descriptive expression	Operation control program	Calculation expression, Bit conditional expression and branches, Repetition process IF ~ ELSE ~ IEND, SELECT ~ CASE ~ SEND, FOR ~ NEXT		
Transition program		Calculation expression, bit conditional expression, comparison conditional expression			
Execute specification	Number of multi executed programs	Up to 256			
	Number of multi active steps	Up to 256 steps per all programs Executed in Motion main cycle			
	Executed task	Normal task			
		Event task (Execution can be masked.)	Fixed cycle	Executed in fixed cycle (0.22 ms, 0.44 ms, 0.88 ms, 1.77 ms, 3.55 ms, 7.11 ms, 14.2 ms)	
			External interrupt	Executed when input ON is set among the input 16 points of interrupt module QI60	
			PLC interrupt	Executed with interrupt instruction (D (P).GINT) from PLC CPU	
NMI task	Executed when input ON is set among the input 16 points of interrupt module QI60				
Number of I/O points (X/Y)		8192 points			
Number of real I/O points (PX/PY)		256 points			
Number of devices	Internal relays (M)	12288 points			
	Link relays (B)	8192 points			
	Annunciators (F)	2048 points			
	Special relays (SM)	2256 points			
	Data registers (D)	19824 points (advanced synchronous control method), 8192 points (Virtual mode switching control method (SV13))			
	Link registers (W)	8192 points			
	Special registers (SD)	2256 points			
	Motion registers (#)	12288 points			
	Coasting timers (FT)	1 point (888μs)			
	Multiple CPU shared device (U□\G)	Up to 14336 points ^(Note-1)			

(Note-1): The number of usable points will differ depending on the system settings.

Specifications

Advanced synchronous control specifications

Synchronous control

Item		Number of settable axes			
		Q173DSCPU	Q172DSCPU	Q170MSCPU-S1	Q170MSCPU
Input axis	Servo input axis	32 axes/module	16 axes/module		
	Command generation axis	32 axes/module	16 axes/module		
	Synchronous encoder axis	12 axes/module			
Composite main shaft gear		1/output axis			
Main shaft main input axis		1/output axis			
Main shaft sub input axis		1/output axis			
Main shaft gear		1/output axis			
Main shaft clutch		1/output axis			
Auxiliary shaft		1/output axis			
Auxiliary shaft gear		1/output axis			
Auxiliary shaft clutch		1/output axis			
Auxiliary shaft composite gear		1/output axis			
Speed change gear		2/output axis			
Output axis (Cam axis)		32 axes/module	16 axes/module		

Cam control

Item			Specifications			
			Q173DSCPU	Q172DSCPU	Q170MSCPU-S1	Q170MSCPU
Memory capacity	Storage area for cam data		256k bytes			
	Working area for cam data		1024k bytes			
Number of registration			Up to 256 program items (depending on memory capacity, cam resolution and number of coordinates)			
Comment			Up to 32 characters for each cam data			
Cam data	Stroke ratio data type	Cam resolution	256, 512, 1024, 2048, 4096, 8192, 16384, 32768			
		Stroke ratio	-214.7483648 to 214.7483647 [%]			
	Coordinate data type	Coordinate number	2 to 16384			
		Coordinate data	Input value : 0 to 2147483647 Output value : -2147483648 to 2147483647			
Cam auto-generation			Cam for rotary cutter, Easy stroke ratio cam			

Mechanical system program (SV22)

Item			Specifications							
			Q173DSCPU	Q172DSCPU	Q170MSCPU-S1	Q170MSCPU	Q170MSCPU	Q170MSCPU	Q170MSCPU	Q170MSCPU
Control unit	Drive module	Virtual servo motor	pulse							
		Synchronous encoder	pulse							
	Output module	Roller	mm, inch							
		Ball screw	mm, inch							
		Rotary table	Fixed as "degree"							
			mm, inch, degree, pulse							
Mechanical system program	Drive module	Virtual servo motor	32	Total 44	16	Total 28	16	Total 28	16	Total 28
		Synchronous encoder	12		12		12		12	
	Virtual axis	Virtual main shaft	32	Total 64	16	Total 32	16	Total 32	16	Total 32
		Virtual auxiliary input axis	32		16		16		16	
	Transmission module	Gear ^(Note-1)	64		32					
		Clutch ^(Note-1)	64		32					
		Speed change gear ^(Note-1)	64		32					
		Differential gear ^(Note-1)	32		16					
		Differential gear (Connect to the virtual main shaft) ^(Note-2)	32		16					
	Output module	Roller	32	Total 32	16	Total 16	16	Total 16	16	Total 16
		Ball screw	32		16		16		16	
		Rotary table	32		16		16		16	
		Cam	32		16		16		16	
Cam	Types		Up to 256							
	Resolution per cycle		256, 512, 1024, 2048							
	Memory capacity		132k bytes							
	Stroke resolution		32767							
	Control mode		Two-way cam, Feed cam							

(Note-1): Use only one module for one output module. (one gear, clutch, speed change gear or differential gear module for one output module).

(Note-2): The differential gears connected to the virtual main shaft can be used only one module per one main shaft.

Performance specification of PLC CPU control area (Q170MSCPU(-S1))

Item		Specifications	
		Q170MSCPU-S1	Q170MSCPU
PLC CPU area		Q06UDHCPU or equivalent	Q03UDCPU or equivalent
Control method		Stored program repeat operation	
I/O control mode		Refresh mode	
Sequence control language		Relay symbol language (ladder), Logic symbolic language (list), MELSP3 (SFC), MELSP-L, Structured text (ST)	
Processing speed (Sequence instruction)	LD instruction	9.5ns	20ns
	MOV instruction	19ns	40ns
	PC MIX value (instruction/μs)	60	28
	Floating point addition	0.057μs	0.12μs
Total number of instructions		858	
Operation (floating point operation) instruction		Yes	
Character string processing instruction		Yes	
PID instruction		Yes	
Special function instruction (Trigonometric function, square root, exponential operation, etc.)		Yes	
Constant scan		0.5 to 2000ms (setting available in units of 0.5ms)	
Program capacity		60k steps (240 kbytes)	30k steps (120 kbytes)
CPU shared memory	QCPU standard memory	8k bytes	
	Multiple CPU high speed transmission area	32k bytes	
Number of I/O device points [X/Y]		8192 points	
Number of I/O points [X/Y]		4096 points	
Internal relay [M]	Points by default (Changeable by parameter)	8192 points	
Latch relay [L]		8192 points	
Link relay [B]		8192 points	
Timer [T]		2048 points	
Retentive timer [ST]		0 points	
Counter [C]		1024 points	
Data register [D]		12288 points	
Link register [W]		8192 points	
Annunciator [F]		2048 points	
Edge relay [V]		2048 points	
Link special relay [SB]		2048 points	
Link special register [SW]		2048 points	
File register [R, ZR]		393216 points	
Step relay [S]		8192 points	
Index register/Standard device register [Z]	20 points		
Index register [Z] (32-bit modification specification of ZR indexing)	Up to 10 points (Z0 to Z18) (Index register [Z] is used in double words.)		
Pointer [P]	4096 points		
Interrupt pointer [I]	256 points		
Special relay [SM]	2048 points		
Special register [SD]	2048 points		
Function input [FX]	16 points		
Function output [FY]	16 points		
Function register [FD]	5 points		
Local device	Yes		
Device initial values	Yes		
Extension base unit	Up to 7 (up to 64 slots)		
PC type when program is made by GX Works2		Q06UDHCPU	Q03UDCPU

Specifications

Module specification

Motion CPU module Q173DSCPU / Q172DSCPU



Item		Specifications	
		Q173DSCPU	Q172DSCPU
Number of control axes		Up to 32 axes	Up to 16 axes
Servo amplifier connection system		SSCNET III/H (2 systems)	SSCNET III/H (1 system)
Maximum overall cable distance [m(ft.)]		SSCNET III/H : 1600 (5249.34), SSCNET III : 800 (2624.67)	
Maximum distance between stations [m(ft.)]		SSCNET III/H : 100 (328.08), SSCNET III : 50 (164.04)	
Peripheral I/F		PERIPHERAL I/F (Motion CPU), USB/RS-232/Ethernet (Via PLC CPU)	
Manual pulse generator operation function		Possible to connect 3 modules	
Synchronous encoder operation function		Possible to connect 12 modules ^(Note-1) (SV22 use)	
Controllable modules	Q172DLX	Up to 4 modules per CPU	Up to 2 modules per CPU
	Q172DEX	Up to 6 modules per CPU (SV22 use)	
	Q173DPX	Up to 4 modules per CPU (Incremental synchronous encoder use in SV22)	
	Q173DSXY	Up to 1 module per CPU (Only manual pulse generator use)	
	Input/output module	Up to 3 modules	
	Analogue module	Total : Up to 256 points per CPU	
QI60		Up to 1 module per CPU	
Input signal	Number of input points	4 points	
	Input method	Positive Common/ Negative Common Shared Type (Photocoupler isolation)	
	Rated input voltage/current	24VDC/Approx. 5 mA	
	Operating voltage range	21.6 to 26.4VDC (24VDC \pm 10%, ripple ratio 5% or less)	
	ON voltage/current	17.5VDC or more/3.5mA or more	
	OFF voltage/current	5VDC or less/0.9mA or less	
	Input resistance	Approx. 5.6k Ω	
	Response time	1ms or less (OFF \rightarrow ON, ON \rightarrow OFF)	
Recommended wire size		AWG18 to AWG22	
Forced stop input signal	Number of input points	1 point	
	Input method	Sink/ Source (Photocoupler isolation)	
	Rated input voltage/current	24VDC/Approx. 2.4 mA	
	Operating voltage range	20.4 to 26.4 VDC (+10/-15 %, ripple ratio 5 % or less)	
	ON voltage/current	17.5 VDC or more/ 2.0 m A or more	
	OFF voltage/current	1.8 VDC or less/ 0.18m A or less	
	Input resistance	Approximately 10k Ω	
	Response time	1ms or less (OFF \rightarrow ON, ON \rightarrow OFF)	
Recommended wire size		AWG22	
Manual pulse generator/incremental synchronous encoder signal	Signal input form	Phase A/ Phase B (magnification by 4)	
	Input frequency	Up to 1Mpps (After magnification by 4, up to 4Mpps) (Differential-output type) Up to 200kpps (After magnification by 4, up to 800kpps) (Voltage-output/Open-collector type)	
Extension base unit		Up to 7	
5VDC internal current consumption [A]		1.75	1.44
Mass [kg]		0.38	
Exterior dimensions [mm(inch)]		120.5 (4.74)(H) \times 27.4 (1.08)(W) \times 120.3 (4.74)(D)	

(Note-1): Up to 12 of manual pulse generators and synchronous encoders can be used in total.

Stand-alone Motion controller Q170MSCPU / Q170MSCPU-S1



Item	Specifications	
	Q170MSCPU-S1	Q170MSCPU
Number of control axes	Up to 16 axes	
Servo amplifier connection system	SSCNET III/H (1 system)	
Maximum overall cable distance [m(ft.)]	SSCNET III/H : 1600 (5249.34), SSCNET III : 800 (2624.67)	
Maximum distance between stations [m(ft.)]	SSCNET III/H : 100 (328.08), SSCNET III : 50 (164.04)	
Peripheral I/F	PERIPHERAL I/F (Motion CPU control area), USB/RS-232 (PLC CPU control area)	
Manual pulse generator operation function	Possible to connect 3 modules	
Synchronous encoder operation function	Possible to connect 12 modules ^(Note-1) (SV22 use)	
Controllable modules	Q172DLX	Up to 2 modules per CPU
	Q173DPX	Up to 4 modules per CPU (Incremental synchronous encoder use in SV22)
		Up to 1 module per CPU (Only manual pulse generator use)
	Input/output module	Total : Up to 256 points per CPU
	Analogue module	
QI60	Up to 1 module per CPU	
Input signal	Number of input points	4 points
	Input method	Positive Common/ Negative Common Shared Type (Photocoupler isolation)
	Rated input voltage/current	24VDC/ Approx. 5mA
	Operating voltage range	21.6 to 26.4VDC (24VDC \pm 10%, ripple ratio 5% or less)
	ON voltage/current	17.5VDC or more/3.5mA or more
	OFF voltage/current	5VDC or less/0.9mA or less
	Input resistance	Approx. 5.6k Ω
	Response time	1ms or less (OFF \rightarrow ON, ON \rightarrow OFF)
	Recommended wire size	AWG18 to AWG22
Forced stop input signal	Number of input points	1 point
	Input method	Sink/ Source (Photocouple isolation)
	Rated input voltage/current	24VDC/Approx. 2.4mA
	Operating voltage range	20.4 to 26.4 VDC (+10/-15 %, ripple ratio 5 % or less)
	ON voltage/current	17.5 VDC or more/ 2.0 mA or more
	OFF voltage/current	1.8 VDC or less/ 0.18m A or less
	Input resistance	Approximately 10k Ω
Response time	1ms or less (OFF \rightarrow ON, ON \rightarrow OFF)	
Recommended wire size	AWG16 to AWG22	
Manual pulse generator/ incremental synchronous encoder signal	Signal input form	Phase A/ Phase B (magnification by 4)
	Input frequency	Up to 1Mpps (After magnification by 4, up to 4Mpps) (Differential-output type) Up to 200kpps (After magnification by 4, up to 800kpps) (Voltage-output/Open-collector type)
Memory card interface	Internal interface	
Extension base unit	Up to 7	
24VDC internal current consumption [A]	1.4	
Mass [kg]	0.8	
Exterior dimensions [mm(inch)]	186(7.32)(H) \times 52(2.05)(W) \times 135(5.31)(D)	

(Note-1): Up to 12 of manual pulse generators and synchronous encoders can be used in total.

Specifications

Servo external signals interface module Q172DLX



Item		Specifications
External input signal (FLS, RLS, STOP, DOG)	Number of input points	Servo external control signals : 32 points, 8 axes
	Input method	Positive Common/ Negative Common Shared Type (Photocoupler isolation)
	Rated input voltage/current	12VDC/2mA, 24VDC/4mA
	Operating voltage range	10.2 to 26.4 VDC (Ripple ratio 5% or less)
	ON voltage/current	10VDC or more/2.0mA or more
	OFF voltage/current	1.8VDC or less/0.18mA or less
	Response time	FLS, RLS, STOP
DOG		0.4ms, 0.6ms, 1ms (OFF to ON, ON to OFF) CPU parameter setting, default 0.4ms
Number of I/O occupying points		32 points (I/O allocation: Intelligent function module, 32 points)
5VDC internal current consumption [A]		0.06
Mass [kg]		0.15
Exterior dimensions [mm (inch)]		98 (3.86)(H) × 27.4 (1.08)(W) × 90 (3.54)(D)

Note) Motion modules (Q172DLX) cannot be installed in CPU slot and I/O slot 0 to 2 of the main base unit.

Synchronous encoder interface module Q172DEX



Item		Specifications
Serial absolute synchronous encoder input	Number of modules	2 per module
	Applicable encoder	Q171ENC-W8
	Position detection method	Absolute (ABS) data method
	Transmission method	Serial communications (2.5Mbps)
	Back up battery	A6BAT/MR-BAT
	Maximum cable length [m(ft.)]	50(164.04)
Tracking enable input	Number of input points	2 points
	Input method	Positive Common/Negative Common Shared Type (Photocoupler isolation)
	Rated input voltage/current	12VDC/2mA, 24VDC/4mA
	Operating voltage range	10.2 to 26.4 VDC (Ripple ratio 5% or less)
	ON voltage/current	10VDC or more/2.0mA or more
	OFF voltage/current	1.8VDC or less/0.18mA or less
	Response time	0.4ms, 0.6ms, 1ms (OFF to ON, ON to OFF) CPU parameter setting, default 0.4ms
Number of I/O occupying points		32 points (I/O allocation: Intelligent function module, 32 points)
5VDC internal current consumption [A]		0.19
Mass [kg]		0.15
Exterior dimensions [mm (inch)]		98 (3.86)(H) × 27.4 (1.08)(W) × 90 (3.54)(D)

(Note-1) Motion modules (Q172DEX) cannot be installed in CPU slot and I/O slot 0 to 2 of the main base unit.

(Note-2) Install Q172DEX to the main base unit. Do not install to the extension base unit.

Manual pulse generator interface module Q173DPX



Item		Specifications	
Manual pulse generator/ incremental synchronous encoder input	Number of modules	3 per module	
	Voltage-output/ Open-collector type	High-voltage	3.0 to 5.25 VDC
		Low-voltage	0 to 1.0 VDC
	Differential-output type	High-voltage	2.0 to 5.25 VDC
		Low-voltage	0 to 0.8 VDC
	Input frequency	50kpps (Up to 200kpps after magnification by 4)	
	Applicable types	Voltage-output/Open-collector type (5VDC), (Recommended product: MR-HDP01) Differential-output type (26C31 or equivalent)	
	Maximum cable length [m(ft.)]	Voltage-output type: 10(32.79) Differential-output type: 30(98.36)	
Tracking enable input	Number of input points	3 points	
	Input method	Positive Common/Negative Common Shared Type (Photocoupler isolation)	
	Rated input voltage/current	12VDC/2mA, 24VDC/4mA	
	Operating voltage range	10.2 to 26.4 VDC (Ripple ratio 5% or less)	
	ON voltage/current	10VDC or more/2.0mA or more	
	OFF voltage/current	1.8VDC or less/0.18mA or less	
Response time	0.4ms, 0.6ms, 1ms (OFF to ON, ON to OFF) CPU parameter setting, default 0.4ms		
Number of I/O occupying points		32 points (I/O allocation: Intelligent function module, 32 points)	
5VDC internal current consumption [A]		0.38	
Mass [kg]		0.15	
Exterior dimensions [mm (inch)]		98(3.86)(H) × 27.4(1.08)(W) × 90(3.54)(D)	

Note) Motion modules (Q173DPX) cannot be installed in CPU slot and I/O slot 0 to 2 of the main base unit.

Safety signal module Q173DSXY



Item		Specifications
		Q173DSXY
Input signals	Number of input points	32 points × 2 systems (PLC CPU control 32 points + Motion CPU control 32 points, Safety input 20 points × 2 systems, Feedback inputs for outputs 12 points × 2 systems)
	Input isolation method	Photocoupler
	Rated input voltage	24VDC (+10/-10%), Negative Common Type
	Max. input current	Approx. 4mA
	Input resistance	Approx. 8.2kΩ
	Input ON voltage/current	20VDC or more/3mA or more
	Input OFF voltage/current	5VDC or less/1.7mA or less
	Input response time	PLC CPU control I/O: 10ms (digital filter's default value) Motion CPU control I/O: 15ms (CR filter)
	Input common method	32 points/common (separate commons for the PLC CPU control I/O and the Motion CPU control I/O)
Input operation indicator LED	32 points (indication for PLC CPU control)	
Output signals	Number of output points	12 points × 2 systems (PLC CPU control 12 points + Motion CPU control 12 points)
	Output isolation method	Photocoupler
	Rated output voltage	24VDC (+10/-10%), Source type
	Max. load current	(0.1A × 8 points, 0.2A × 4 points) × 2 systems, common current: each connector 1.6A or less
	Max. inrush current	0.7A 10ms or less (1.4A, 10ms or less for 0.2A output pin)
	Response time	1ms or less
	Output common method	12 points/common (separate commons for the PLC CPU control I/O and the Motion CPU control I/O)
Output operation indicator LED	Shared with inputs	
Safety specifications <small>(Note-1)</small>	Functions according to IEC61800-5-2	STO, SS1, SS2, SOS, SLS, SBC, SSM (IEC61800-5-2 : 2007) and Safety I/Os
	Safety performance	EN ISO 13849-1 Category3 PL d, EN 61800-5-2/IEC 61508 Part 1-7 : 1998/2000, EN 62061 SIL CL 2
	Mean time to dangerous failure (MTTFd)	169 years or more (theoretical value)
	Diagnostic converge (DCavq)	Low
	Probability of dangerous Failure per Hour (PFH)	2.17E-8 (1/h)
Number of I/O occupying points	32 points	
Communication between PLC CPUs	Parallel bus communication (via main base unit)	
Communication between Motion CPUs	Serial communication (RS-485), RIO cable	
Number of installed modules	Up to 3 modules (Max. number of input points: 60 points × 2 systems; Max. number of output points: 36 points × 2 systems)	
5VDC internal current consumption	0.20A (TYP. all points ON)	
Mass [kg]	0.15	
Exterior dimensions [mm(inch)]	98 (3.86)(H) × 27.4 (1.08)(W) × 90 (3.54)(D)	

Note) Install Q173DSXY to the main base unit. Do not install to the extension base unit.
 (Note-1): These functions are certified by Certification Body only for the combination of Q173DSXY and "QnUD(E)(H)CPU", the following PLC CPU modules.
 QnUD (E)(H) CPU : Q03UDCPU, Q03UDECPU, Q04UDHCPU, Q04UDEHCPU, Q06UDHCPU, Q06UDEHCPU, Q10UDHCPU, Q10UDEHCPU, Q13UDHCPU, Q13UDEHCPU, Q20UDHCPU, Q20UDEHCPU, Q26UDHCPU, Q26UDEHCPU, Q50UDEHCPU, Q100UDEHCPU

Optical hub unit MR-MV200



Item		Specifications
Number of optical hub module		Up to 16 modules /line
Number of servo amplifier <small>(Note-1)</small>		Up to 16 axes /line
Input power supply	Input voltage [V]	21.6 to 26.4 VDC (24 VDC±10%)
	Input current [A]	0.2
Mounting method		Directly mounted to the control panel or with DIN rail
Cable length [m(ft.)]		Up to 100 (328.08)
Consumption power [W]		4.8
Mass [kg]		0.2
Exterior dimensions [mm(inch)]		168 (6.61)(H) × 30 (1.18)(W) × 100 (3.94)(D)

(Note-1): MR-J4-B, MR-J4W2-B, and MR-J4W3-B are 1-axis, 2-axis, 3-axis amplifiers respectively.

Specifications

Exterior Dimensions

Motion CPU module Q173DSCPU

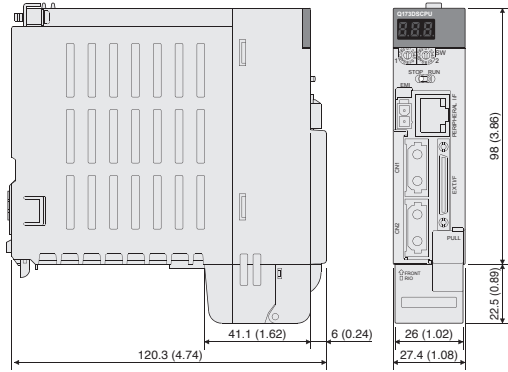

[Unit : mm (inch)]

Motion CPU module Q172DSCPU

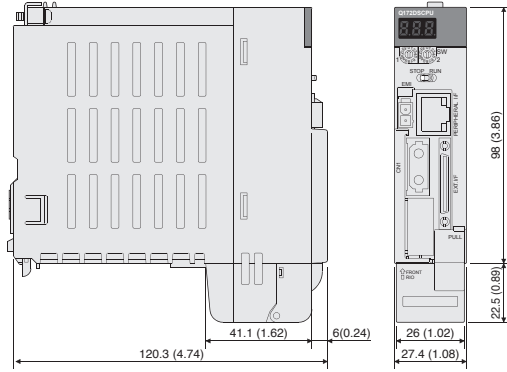

[Unit : mm (inch)]

Servo external signals interface module Q172DLX

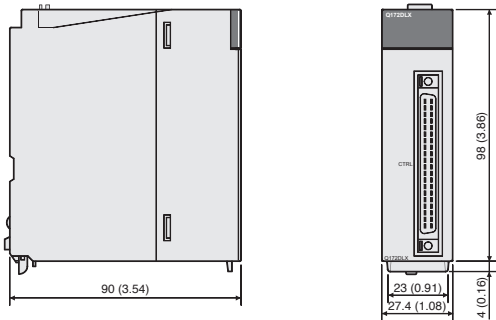

[Unit : mm (inch)]

Synchronous encoder interface module Q172DEX

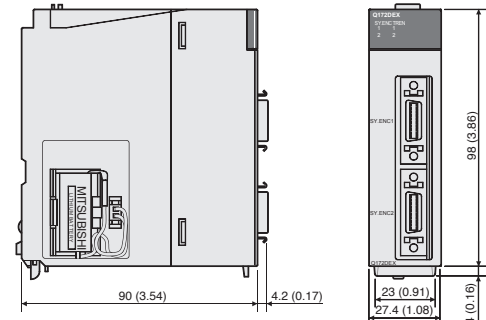

[Unit : mm (inch)]

Manual pulse generator interface module Q173DPX

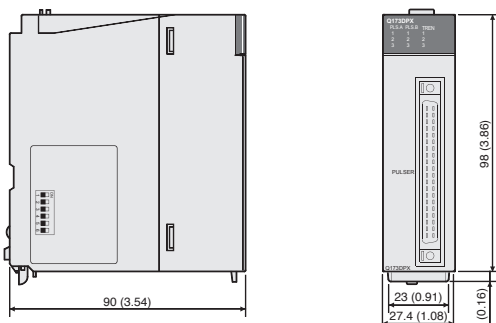

[Unit : mm (inch)]

Safety signal module Q173DSXY

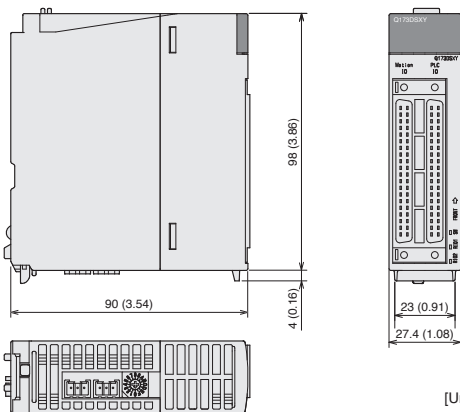

[Unit : mm (inch)]

Optical hub unit MR-MV200

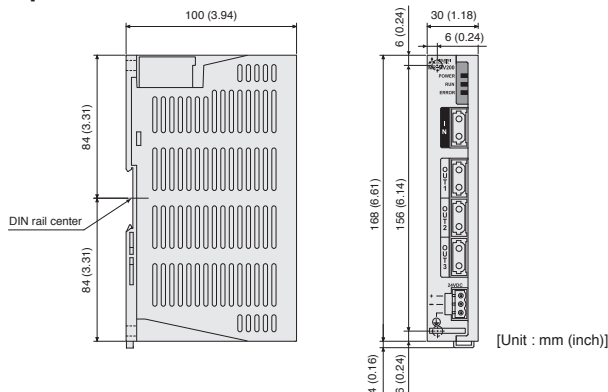

[Unit : mm (inch)]

Motion controller Q170MSCPU

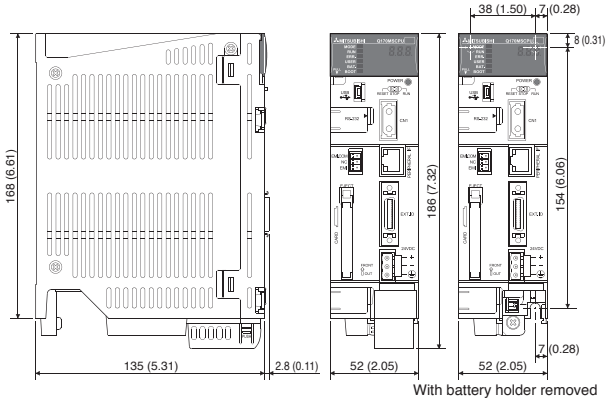

[Unit: mm (inch)]

Motion controller Q170MSCPU-S1

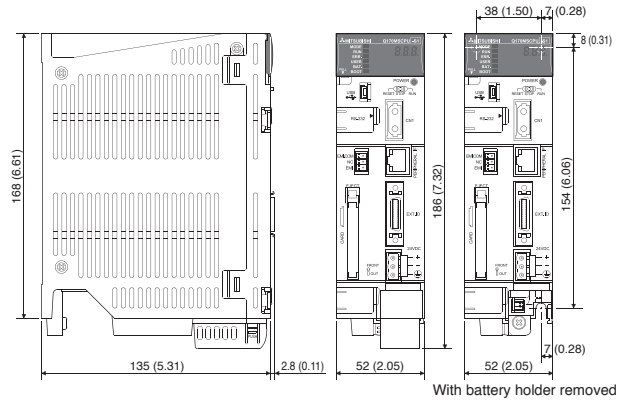

[Unit: mm (inch)]

Serial absolute synchronous encoder Q171ENC-W8

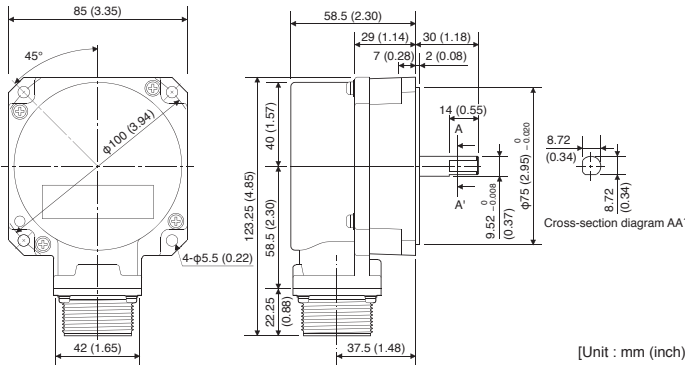

[Unit : mm (inch)]

Item	Specifications
Resolution	4,194,304pulse/rev
Direction of increasing addresses	CCW (viewed from end of shaft)
Protective construction	Dustproof/Waterproof (IP67: Except for the shaft-through portion)
Permitted axial loads	Radial load: Up to 19.6N Thrust load: Up to 9.8N
Permitted speed	3600r/min
Permitted angular acceleration	40000rad/s ²
Ambient temperature	-5 to 55°C (23 to 131°F)
5VDC consumption current	0.25A
Mass	0.6kg

Manual pulse generator MR-HDP01

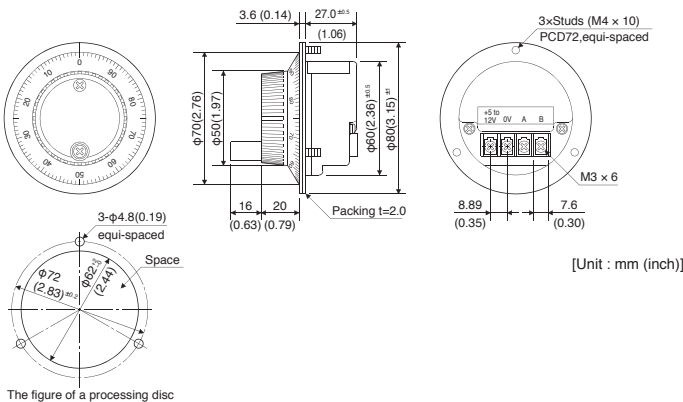

[Unit : mm (inch)]

Item	Specifications
Pulse resolution	25pulse/rev (100pulse/rev after magnification by 4)
Phase A/Phase B Output voltage	Input voltage : -1V or more (Note)
Output method	Voltage output
Output current	Up to 20mA
Life time	1,000,000 revolutions or more (at 200r/min)
Permitted axial loads	Radial load: Up to 19.6N Thrust load: Up to 9.8N
Maximum rotation speed	600r/min (Instantaneous maximum), 200r/min (Normal rotation)
Ambient temperature	-10 to 60°C (14 to 140°F)
5VDC consumption current	0.06A
Mass	0.4kg

(Note) When using an external power supply, use 5VDC power supply.

Specifications

Main base unit

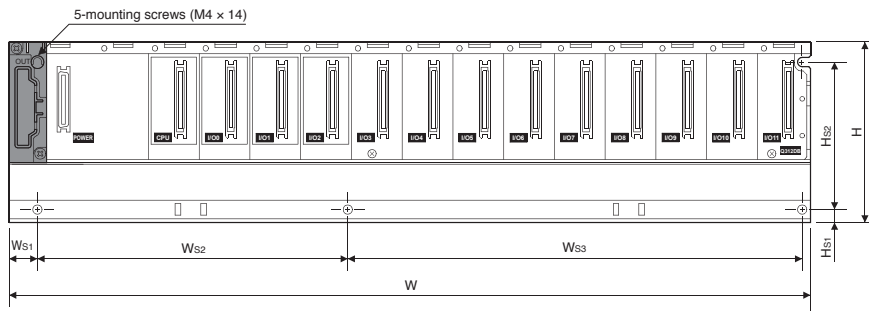

	Q35DB	Q38DB	Q312DB	Q63B	Q65B	Q68B	Q612B
W	245 (9.65)	328 (12.92)	439 (17.30)	189 (7.44)	245 (9.65)	328 (12.92)	439 (17.30)
Ws1	15.5 (0.61)						
Ws2	224.5±0.3 (8.84±0.01)	170±0.3 (6.69±0.01)	170±0.3 (6.69±0.01)	167±0.3 (6.57±0.01)	222.5±0.3 (8.76±0.01)	190±0.3 (7.48±0.01)	190±0.3 (7.48±0.01)
Ws3	(Ws2+Ws3) 5.43±0.01	138±0.3 (5.43±0.01)	249±0.3 (9.80±0.01)	(Ws2+Ws3) 6.57±0.01	(Ws2+Ws3) 8.76±0.01	116±0.3 (4.57±0.01)	227±0.3 (8.94±0.01)
H	98 (3.86)						
Hs1	7 (0.28)						
Hs2	80±0.3 (3.15±0.01)						

[Unit : mm (inch)]

Extension base unit (Note-1)

The power supply unit is not required to use.

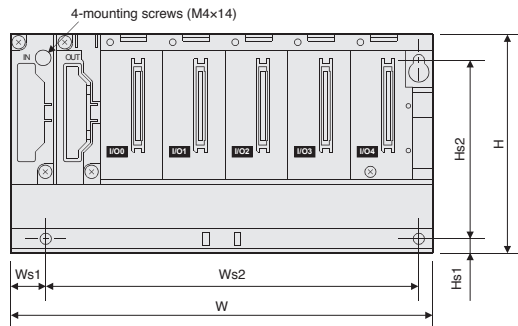

	Q52B	Q55B
W	106(4.17)	189(7.44)
Ws1	15.5(0.61)	
Ws2	83.5±0.3 (3.29±0.01)	167±0.3 (6.57±0.01)
H	98(3.86)	
Hs1	7(0.28)	
Hs2	80±0.3(3.15±0.01)	

[Unit: mm (inch)]

(Note-1): Refer to the exterior dimensions of main base unit in this catalog for the main base unit with the power supply unit.

■ Mounting

Motion controller Q173DSCPU/Q172DSCPU

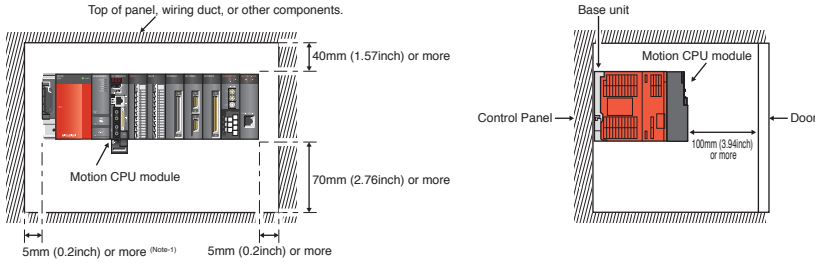

(Note-1): 20mm(0.79inch) or more when the adjacent module is not removed and the extension cable is connected.
 Note) The main base unit cannot be mounted with the DIN rail when using the Motion CPU module.

Stand-alone Motion controller Q170MSCPU(-S1)

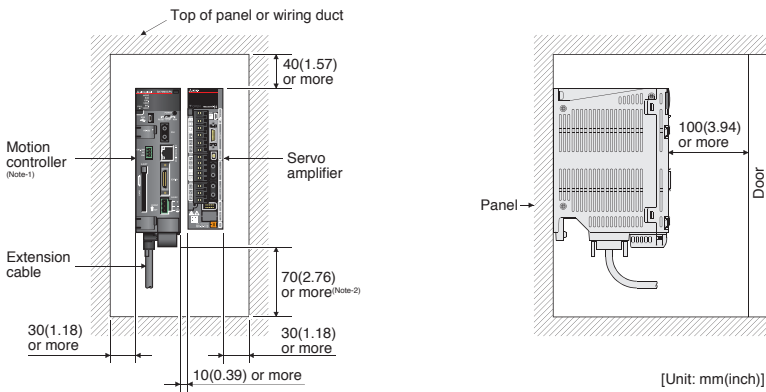

(Note-1): Install the Motion controller at the left side of the servo amplifier.
 (Note-2): 15mm(0.59inch) or more when the extension cable is connected.

Base unit

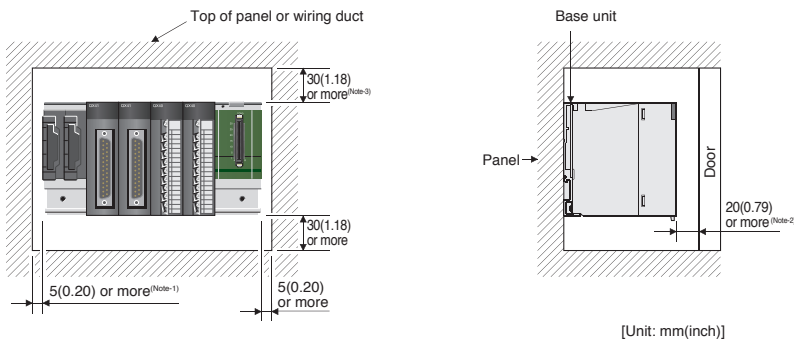

(Note-1): 20mm(0.79inch) or more when the adjacent module is not removed and the extension cable is connected.
 (Note-2): 80mm(3.15inch) or more for the connector type.
 (Note-3): For wiring duct with 50mm(1.97inch) or less height. 40mm(1.57inch) or more for other cases.

Specifications

Component

Motion controller Q173DSCPU/Q172DSCPU

[Motion dedicated equipment]

Part	Model	Description	Standards	
Motion CPU module	Q173DSCPU	Up to 32 axes, Operation cycle 0.22 ms or more (Attachment: battery (Q6BAT))	CE, UL, KC	
	Q172DSCPU	Up to 16 axes, Operation cycle 0.22 ms or more (Attachment: battery (Q6BAT))	CE, UL, KC	
Cable for forced stop input ^(Note-1)	Q170DEMICBL05M	Forced stop input (Be sure to order with Motion CPU modules)	0.5m (1.64ft.)	—
	Q170DEMICBL1M		1m (3.28ft.)	—
	Q170DEMICBL3M		3m (9.84ft.)	—
	Q170DEMICBL5M		5m (16.40ft.)	—
	Q170DEMICBL10M		10m (32.81ft.)	—
	Q170DEMICBL15M		15m (49.21ft.)	—
	Q170DEMICBL20M		20m (65.62ft.)	—
	Q170DEMICBL25M		25m (82.02ft.)	—
Connector for forced stop input cable	Q170DEMICON	Connector for forced stop input cable production (Be sure to order when you make the forced stop input cable)	—	
	MR-J3BUS_M	Q17nDSCPU⇔MR-J4-B MR-J4-B⇔MR-J4-B	Standard cord for inside panel 0.15m (0.49ft.), 0.3m (0.98ft.), 0.5m (1.64ft.), 1m (3.28ft.), 3m (9.84ft.)	—
MR-J3BUS_M-A	Standard cable for outside panel 5m (16.40ft.), 10m (32.81ft.), 20m (65.62ft.)		—	
MR-J3BUS_M-B ^(Note-2)	Long distance cable 30m (98.43ft.), 40m (131.23ft.), 50m (164.04ft.)		—	
Servo external signals interface module	Q172DLX	Servo external signal inputs for 8 axes (FLS, RLS, STOP, DOG × 8)	CE, UL, KC	
Synchronous encoder interface module	Q172DEX	Serial absolute synchronous encoder Q171ENC-W8 interface × 2, Tracking input 2 points, with A6BAT	CE, UL, KC	
Manual pulse generator interface module	Q173DPX	Manual pulse generator MR-HDP01/Incremental synchronous encoder interface × 3, Tracking input 3 points	CE, UL, KC	
Safety signal module	Q173DSXY	Input: 20 points (2 systems), Output: 12 points (2 systems), Attachment RIO cable (Q173DSXYCBL01M)	CE, UL, KC	
Optical hub unit	MR-MV200	Three branches/unit, DC power supply connector enclosed	CE, UL, KC	
Serial absolute synchronous encoder	Q171ENC-W8	Resolution: 4,194,304pulse/rev, Permitted speed: 3600r/min	CE, UL, KC	
Serial absolute synchronous encoder cable	Q170ENCCBL2M	Serial absolute synchronous encoder Q171ENC-W8⇔Q172DEX	2m (6.56ft.)	—
	Q170ENCCBL5M		5m (16.40ft.)	—
	Q170ENCCBL10M		10m (32.81ft.)	—
	Q170ENCCBL20M		20m (65.62ft.)	—
	Q170ENCCBL30M		30m (98.43ft.)	—
	Q170ENCCBL50M		50m (164.04ft.)	—
	Q170ENCCBL2M-A	Serial absolute synchronous encoder Q171ENC-W8⇔MR-J4-RJ	2m (6.56ft.)	—
	Q170ENCCBL5M-A		5m (16.40ft.)	—
	Q170ENCCBL10M-A		10m (32.81ft.)	—
	Q170ENCCBL20M-A		20m (65.62ft.)	—
	Q170ENCCBL30M-A		30m (98.43ft.)	—
	Q170ENCCBL50M-A		50m (164.04ft.)	—
Internal I/F connector set	Q170DSIOCON	Manual pulse generator/incremental synchronous encoder interface, external command signal/interface for switching signals, With ferrite core (This set is not included with the Motion CPU module.)	—	
RIO cable	Q173DSXYCBL01M	Q17nDSCPU⇔Q173DSXY	0.1m (0.44ft.)	—
	Q173DSXYCBL05M	Q173DSXY⇔Q173DSXY	0.5m (1.64ft.)	—
Battery	Q6BAT	For memory data backup of SRAM built-in Motion CPU (program, parameter, absolute position data, latch data)	—	
	A6BAT	For data backup of Q171ENC-W8	—	
Manual pulse generator	MR-HDP01	Number of pulses per revolution: 25pulse/rev (100pulse/rev after magnification by 4) Permitted speed: 200r/min (Normal rotation)	—	

(Note-1): Be sure to use the cable for forced stop input. The forced stop cannot be released without using it.

(Note-2): For long distance cable up to 100m (328.08ft.) and ultra-long bending life cable, contact Mitsubishi Electric System & Service Co., Ltd.

[Sales office] FA PRODUCT DIVISION mail: osb.webmaster@melsc.jp

(Note-3): "-" indicates cable length (015: 0.15m (0.49ft.), 03: 0.3m (0.98ft.), 05: 0.5m (1.64ft.), 1: 1m (3.28ft.), 3: 3m (9.84ft.), 5: 5m (16.40ft.), 10: 10m (32.81ft.), 20: 20m (65.62ft.), 30: 30m (98.43ft.), 40: 40m (131.23ft.), 50: 50m (164.04ft.))

Stand-alone Motion controller Q170MSCPU(-S1)

[Motion dedicated equipment]

Part	Model	Description	Standards		
Stand-alone Motion controller	Q170MSCPU	Integrated with power supply, PLC CPU, and Motion CPU	CE, UL, KC		
	Q170MSCPU-S1	Attachment: battery (Q6BAT), 24VDC power supply connector, emergency stop input cable connector ^(Note-1)	CE, UL, KC		
SSCNET III cable ^(Note-3)	MR-J3BUS_M	Q170MSCPU(-S1)⇔MR-J4-B MR-J4-B⇔MR-J4-B	Standard cord for inside panel	0.15m (0.49ft.), 0.3m (0.98ft.), 0.5m (1.64ft.), 1m (3.28ft.), 3m (9.84ft.)	—
	MR-J3BUS_M-A		Standard cable for outside panel	5m (16.40ft.), 10m (32.81ft.), 20m (65.62ft.)	—
	MR-J3BUS_M-B ^(Note-2)		Long distance cable	30m (98.43ft.), 40m (131.23ft.), 50m (164.04ft.)	—
Servo external signals interface module	Q172DLX	Servo external signal inputs for 8 axes (FLS, RLS, STOP, DOG × 8)	CE, UL, KC		
Manual pulse generator interface module	Q173DPX	Manual pulse generator MR-HDP01/ Incremental synchronous encoder interface ×3, Tracking input 3 points	CE, UL, KC		
Optical hub unit	MR-MV200	Three branches/unit, DC power supply connector enclosed	CE, UL, KC		
Serial absolute synchronous encoder	Q171ENC-W8	Resolution: 4,194,304pulse/rev, Permitted speed: 3600r/min	CE, UL, KC		
Serial absolute synchronous encoder cable	Q170ENCCBL2M-A	Serial absolute synchronous encoder Q171ENC-W8⇔ Servo amplifier MR-J4-B-RJ	2m (6.56ft.)	—	
	Q170ENCCBL5M-A		5m (16.40ft.)	—	
	Q170ENCCBL10M-A		10m (32.81ft.)	—	
	Q170ENCCBL20M-A		20m (65.62ft.)	—	
	Q170ENCCBL30M-A		30m (98.43ft.)	—	
	Q170ENCCBL50M-A		50m (164.04ft.)	—	
Internal I/F connector set	LD77MHIOCON	Manual pulse generator/Incremental synchronous encoder interface, external command signal/Switching signal interface (This set is not included with the Q170MSCPU(-S1).)	—		
Battery	Q6BAT	For memory data backup of SRAM built-in Motion controller (program, parameter, absolute position data, latch data)	—		
Large capacity battery	Q7BAT		—		
Battery holder	Q170MSBAT-SET	Battery holder for Q7BAT (included with the battery)	—		
Manual pulse generator	MR-HDP01	Number of pulses per revolution: 25pulse/rev (100pulse/rev after magnification by 4) Permitted speed: 200r/min (Normal rotation)	—		

(Note-1): Be sure to use the cable for forced stop input. The forced stop cannot be released without using it.

(Note-2): For long distance cable up to 100m (328.08ft.) and ultra-long bending life cable, contact Mitsubishi Electric System & Service Co., Ltd. [Sales office] FA PRODUCT DIVISION mail: osb.webmaster@melsc.jp

(Note-3): " " indicates cable length (015: 0.15m (0.49ft.), 03: 0.3m (0.98ft.), 05: 0.5m (1.64ft.), 1: 1m (3.28ft.), 3: 3m (9.84ft.), 5: 5m (16.40ft.), 10: 10m (32.81ft.), 20: 20m (65.62ft.), 30: 30m (98.43ft.), 40: 40m (131.23ft.), 50: 50m (164.04ft.))

[PLC common equipment]

Part	Model
PLC CPU module ^(Note-1)	Q03UDCPU, Q03UDECPU, Q04UDHCPU, Q04UDEHCPU, Q06UDHCPU, Q06UDEHCPU, Q10UDHCPU, Q10UDEHCPU, Q13UDHCPU, Q13UDEHCPU, Q20UDHCPU, Q20UDEHCPU, Q26UDHCPU, Q26UDEHCPU, Q50UDEHCPU, Q100UDEHCPU, Q03UDVCPU, Q04UDVCPU, Q06UDVCPU, Q13UDVCPU, Q26UDVCPU
C Controller CPU module ^(Note-1)	Q12DCCPU-V, Q24DHCCPU-V, Q24DHCPU-LS
Main base unit ^(Note-1)	Q35DB, Q38DB, Q312DB
Extension base unit	Q63B, Q65B, Q68B, Q612B, Q52B, Q55B
Extension cable	QC05B, QC06B, QC12B, QC30B, QC50B, QC100B
Power supply module ^(Note-2)	Q61P, Q62P, Q63P, Q64PN
Input/output module	Input module, Output module, Input/output composite module
Analog module	Q68ADV, Q62AD-DGH, Q66AD-DG, Q68ADI, Q64AD, Q64AD-GH, Q68AD-G, Q68DAVN, Q68DAIN, Q62DAN, Q62DA-FG, Q64DAN, Q66DA-G
Interrupt module	QI60
High-speed counter	QD62D, QD65PD2
Positioning module	QD75P1, QD75P2, QD75P4, QD75D1, QD75D2, QD75D4, QD75MH1, QD75MH2, QD75MH4
Simple Motion module	QD77MS2, QD77MS4, QD77MS16
Control unit of displacement sensor	UQ1-01, UQ1-02

(Note-1): Needed when the Q173DSCPU/Q172DSCPU is used.

(Note-2): Use the power supply module within its capacity.

Software for Motion controller

[Operating system software] ^(Note-1)

Application	Model name			
	Q173DSCPU	Q172DSCPU	Q170MSCPU-S1	Q170MSCPU
Conveyor assembly use SV13	SW8DNC-SV13QJ	SW8DNC-SV13QL	SW8DNC-SV13QN	
Automatic machinery use SV22	SW8DNC-SV22QJ	SW8DNC-SV22QL	SW8DNC-SV22QN	

Product	Model name	Description
Operating system software set for Q17nDSCPU/Q170MSCPU	SW8DNC-SV1322QJLSET	SW8DNC-SV13QJ, SW8DNC-SV13QL, SW8DNC-SV13QN, SW8DNC-SV22QJ, SW8DNC-SV22QL, SW8DNC-SV22QN

(Note-1): Operating system software (SV22) is Pre-installed into Motion controller before shipment

SW8DNC-SV1322QJLSET [CD-ROM] that includes all operating system softwares in the table above is also available.

SSCNET III/H compatible
MELSEC-Q series Simple Motion module
QD77MS16/QD77MS4/QD77MS2



Achieving Various Controls While Being Simple to Use Just Like Positioning Modules

- Advanced and wide-range Motion controls can be easily performed just with a sequence program, such as advanced synchronous control, cam control, and speed-torque control (tightening & press-fit control).
- Equipped with the synchronous encoder input and mark detection function as standard.
- Simple settings without programming are achieved with Mitsubishi's MELSOFT series Engineering environment.
- QD75MH existing project assets can be diverted to QD77MS.

[System configuration]

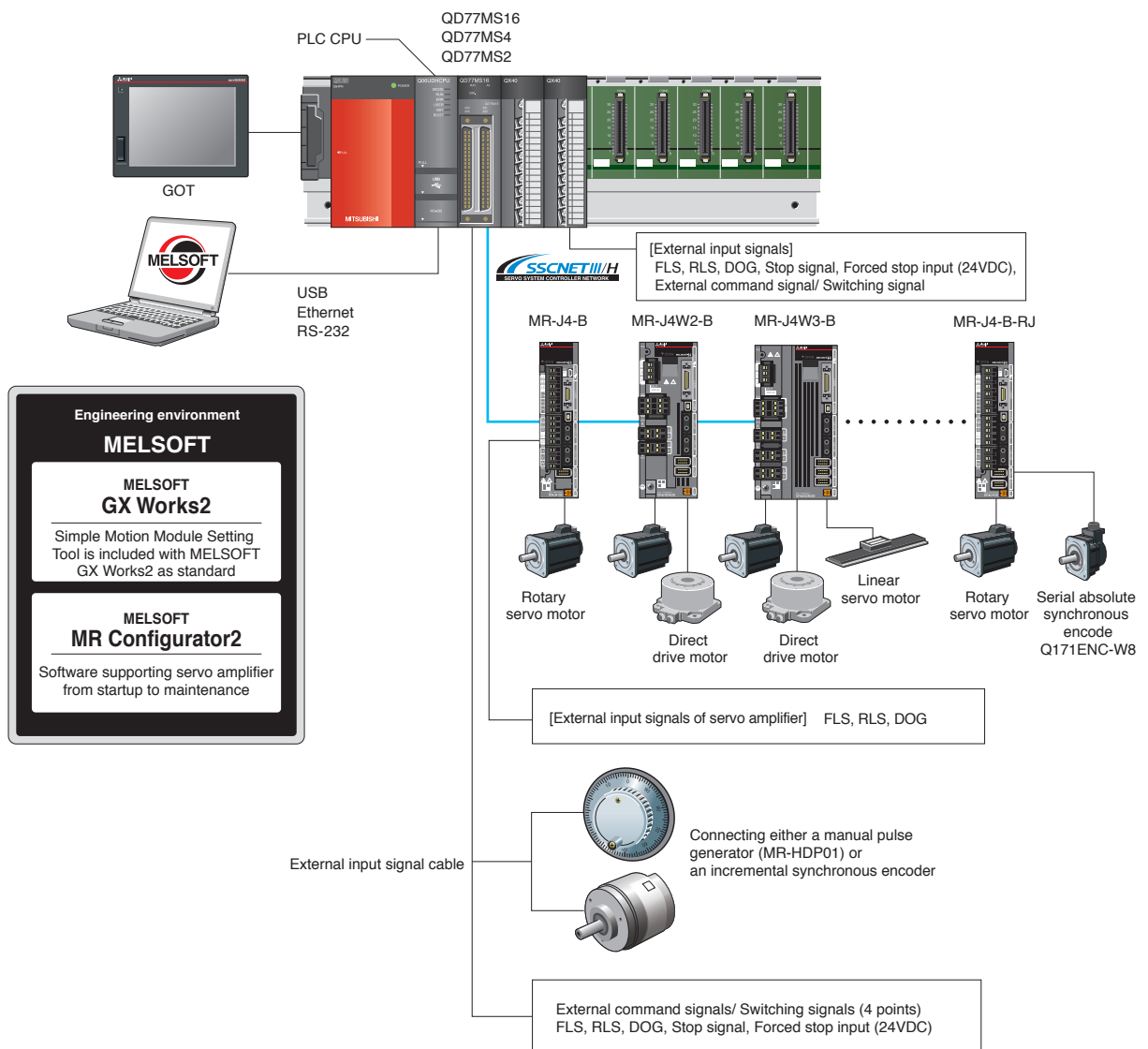

SSCNET III/H compatible
MELSEC-L series Simple Motion module
LD77MS16/LD77MS4/LD77MS2

Motion Control Made Simpler



- Advanced and wide-range Motion controls can be easily performed just with a sequence program, such as advanced synchronous control, cam control, and speed-torque control (tightening & press-fit control).
- Equipped with the synchronous encoder input and mark detection function as standard.
- Simple settings without programming are achieved with Mitsubishi's MELSOFT series Engineering environment.
- LD77MH existing project assets can be diverted to LD77MS.

[System configuration]

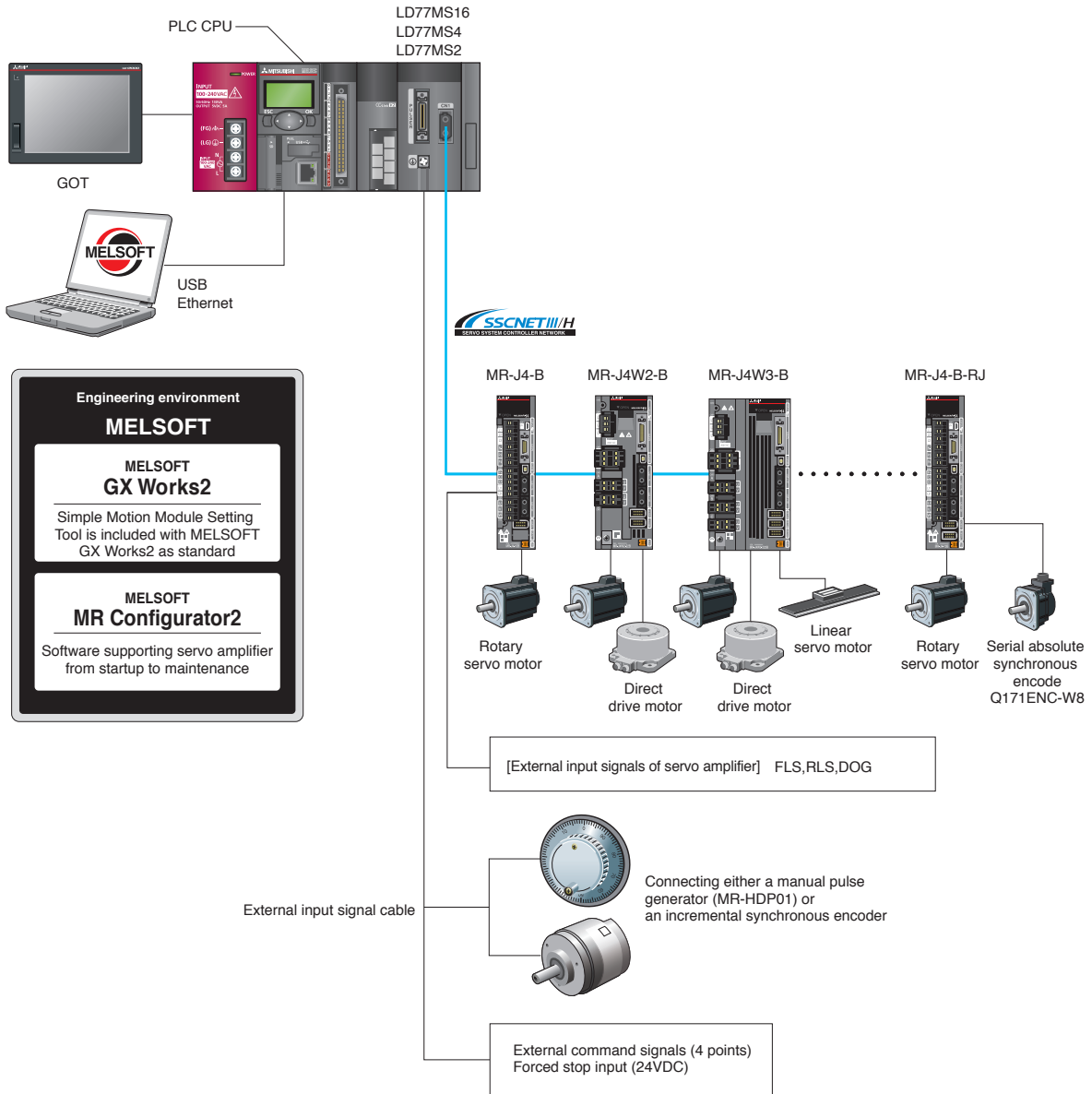

CC-Link IE Field Network
MELSEC-Q series Simple Motion module
QD77GF16



Superior Motion Performance Now Available for CC-Link IE Field Network

- Positioning/advanced synchronous/cam controls are easily performed with simple parameter setting and a start from a sequence program.
- QD77GF16 can be used as the master station of CC-Link IE Field Network. (equivalent to QJ71GF11-T2) (Note-1)
- Within one network, QD77GF16 can communicate with servo amplifiers and field devices (Remote I/O, Sensor, etc.).

(Note-1): QD77GF can be used only as the master station. Line and star topologies are available. Up to 104 slave devices can be connected in one network.

[System configuration]

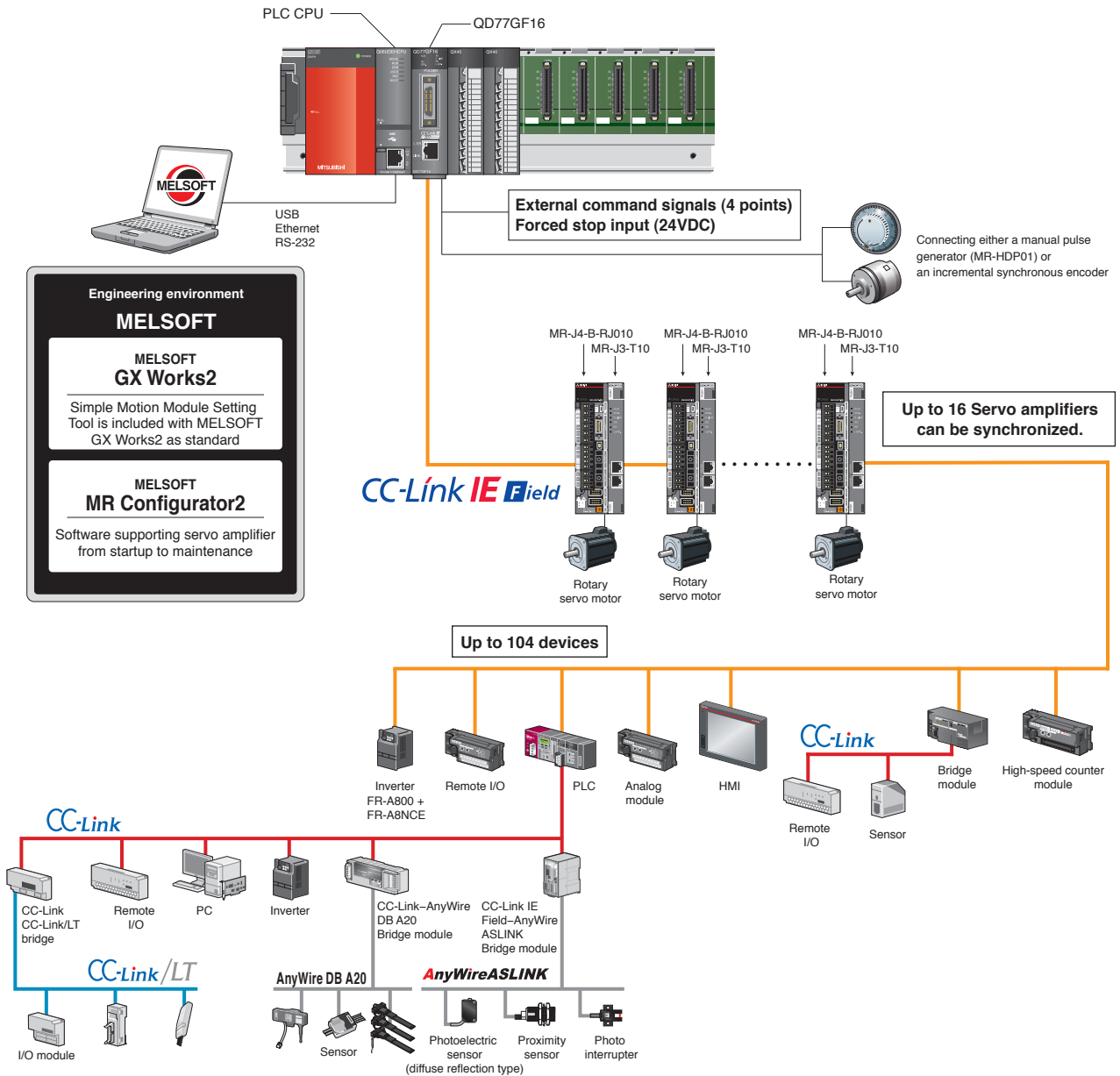

MEMO

Lined area for writing notes, containing 22 horizontal lines.

Outline

Motion Controller

Simple Motion

Network

Servo Amplifier

Engineering Environment

Features

Control Flow

QD77MS LD77MS
QD77GF

The start of positioning operation by the Simple Motion module is programmed in PLC CPU.

The Simple Motion module starts operation from the designated positioning data No. and continues operation until the operation pattern ends.

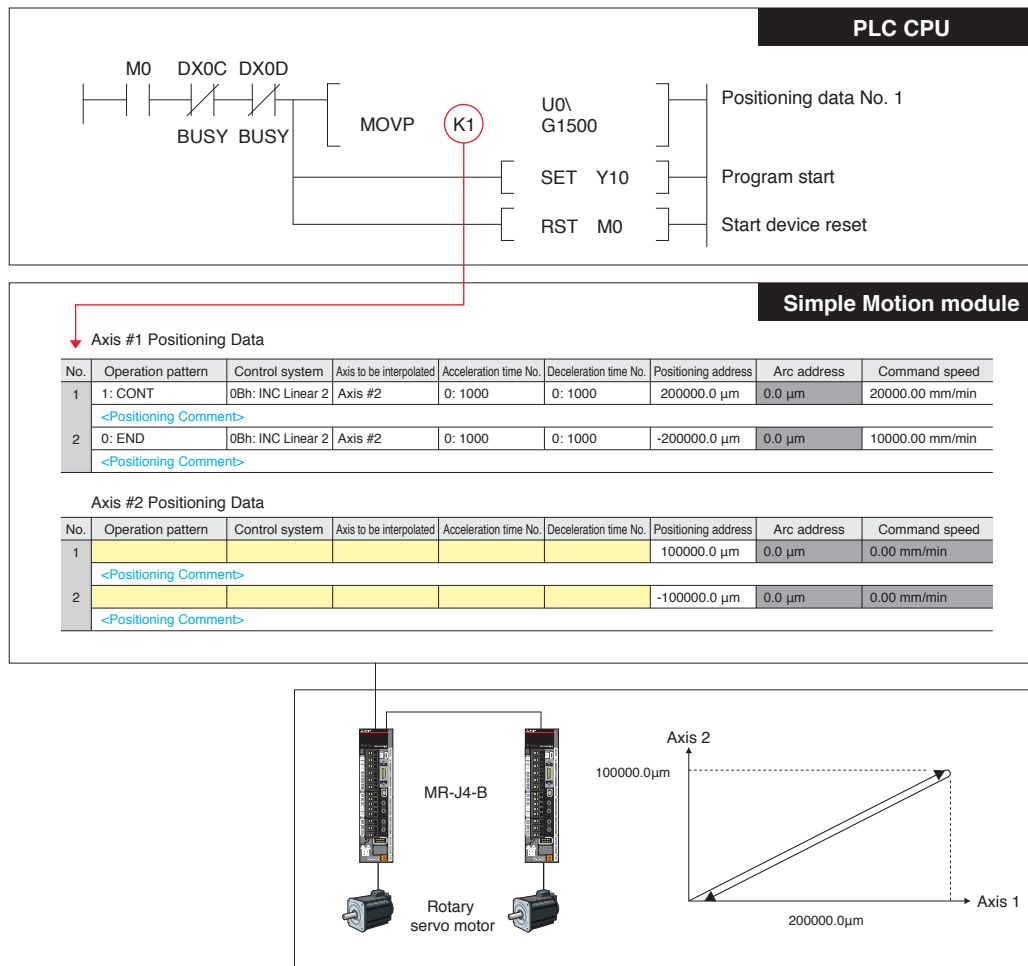

High Compatibility with the Previous Models

QD77MS LD77MS

The Positioning module (QD75MH) projects and sequence programs are easily diverted to the Simple Motion module (QD77MS/LD77MS).

The replacement to QD77MS/LD77MS is easily completed without replacing the prior model of servo amplifier MR-J3-B.

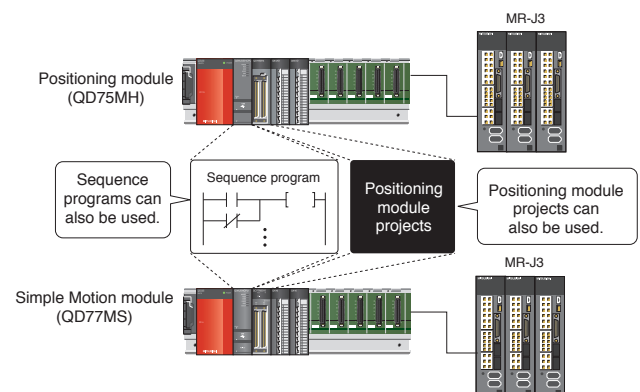

Equipped with Various Functions in the Compact Modules

QD77MS LD77MS
QD77GF

The incremental synchronous encoder interface and the mark detection signal interface are integrated in the Simple Motion modules. Therefore no option module is required.

- Synchronous control with synchronous encoder
Select the synchronous encoder to be used from either the incremental synchronous encoder using the LD77MS built-in interface, or the absolute synchronous encoder via servo amplifier. The synchronization accuracy is improved further with the phase compensation function, designed to compensate for synchronous encoder delays.

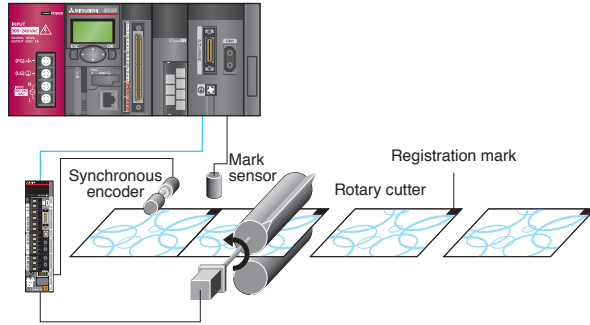

[Example of using an absolute synchronous encoder via a servo amplifier]

- Mark detection function
This function detects registration marks on the high-speed moving packing film by sensor and sets the current position to the buffer memory. Any fluctuation errors between the current sensed position and the reference position are compensated, and the packing material is cut at the set position.

Synchronous Communication Function

QD77GF

The operation timing between multiple slave units is aligned since the synchronous communication compatible slave devices can operate while synchronizing to the operation cycle of the Simple Motion module. Synchronous control is achieved by calculating the data of each slave device with the PLC CPU interrupt task and then setting the command value for the next amplifier. The slave devices that are compatible with this synchronous communication function include DC inputs, transistor outputs, analog I/Os, and high-speed counter modules.

[In case that the high-speed counter module reads the data from the synchronous encoder for synchronous control.]

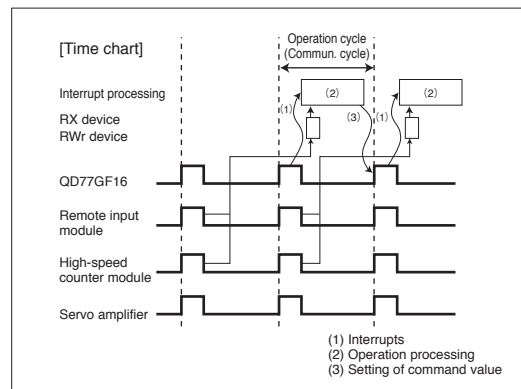
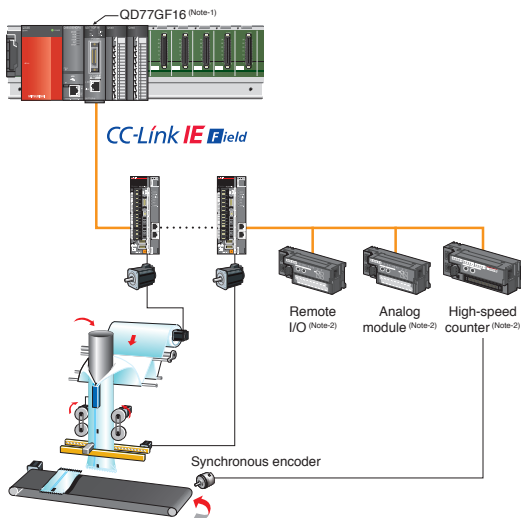

(Note-1): The units with serial number of 15092 or later (upper 5 digits) are compatible with this function.
(Note-2): The units with serial number of 15102 or later (upper 5 digits) are compatible with this function.

Features

Positioning Control

QD77MS	LD77MS
QD77GF	

- To respond to various applications, a machine can be controlled by various control methods such as linear interpolation control, 2-axis circular interpolation control, fixed-pitch feed control, and continuous trajectory control.
- Automatic operation can be executed by setting the positioning addresses and speeds, etc., to a sequence program.
- Powerful sub-functions are available such as M codes, skip function, speed change function, and target position change function.

Sealing

- Continuous trajectory control
- Linear/circular interpolation
- Synchronous control
- High-speed, high-accuracy trajectory calculation

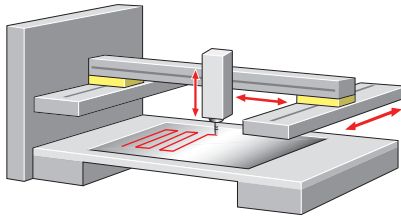

X-Y table

- 2-axis linear interpolation
- 2-axis circular interpolation
- 3-axis linear interpolation
- Continuous trajectory control

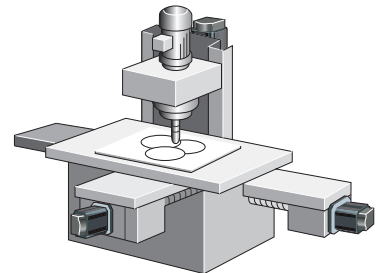

Advanced Synchronous/Cam Controls

QD77MS	LD77MS
QD77GF	

The workpiece handled from line 1 is transferred to the relay point by robot 1. After robot 1 returns to its original position, the workpiece at the relay point is moved to line 2 by robot 2. Robot 1 and robot 2 need to check the position each other when handling the work pieces, which makes tact time longer. In cam control, the robot positions are determined by the cam pattern, so the robots can efficiently handle the work pieces.

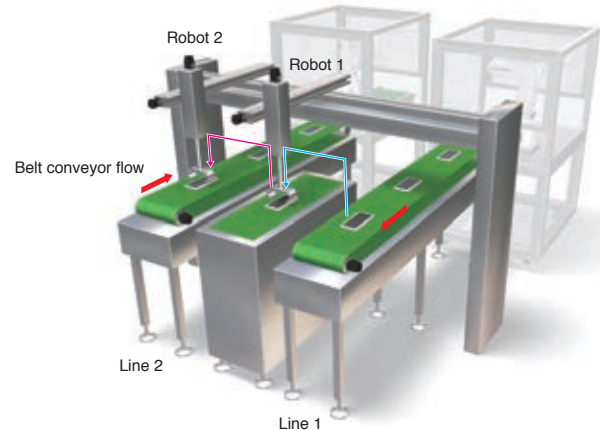
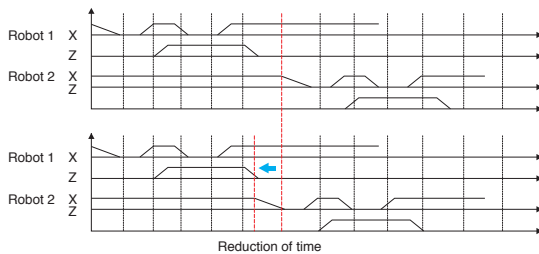

Speed-torque Control (Tightening & Press-fit Control)

Tightening & Press-fit control Patent pending

QD77MS	LD77MS
QD77GF	

Tension control application such as unwinding and rewinding are available with the Simple Motion module. Since the current position is controlled even during the speed-torque control, the positioning based on the absolute position coordinates is possible after switching from the speed-torque control back to the position control.

(Note): The tightening & press-fit control can be achieved with QD77MS/LD77MS.

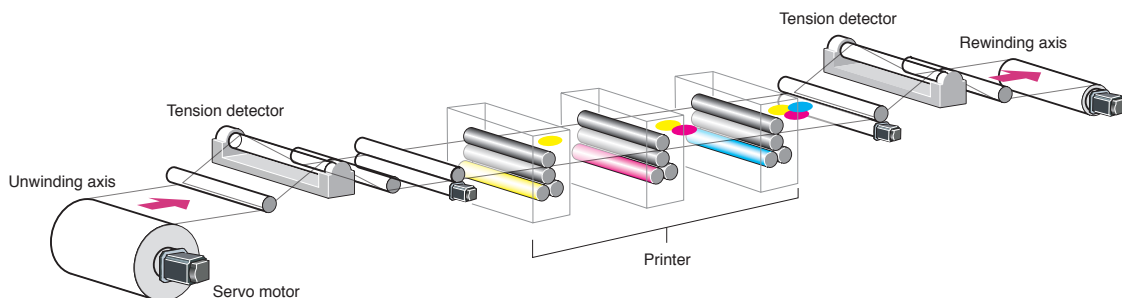

Cam Auto-generation Function

QD77MS LD77MS
QD77GF

The cam data for the rotary cutter is created easily just by entering the sheet length, synchronization width and cam resolution, etc., in the sequence program.

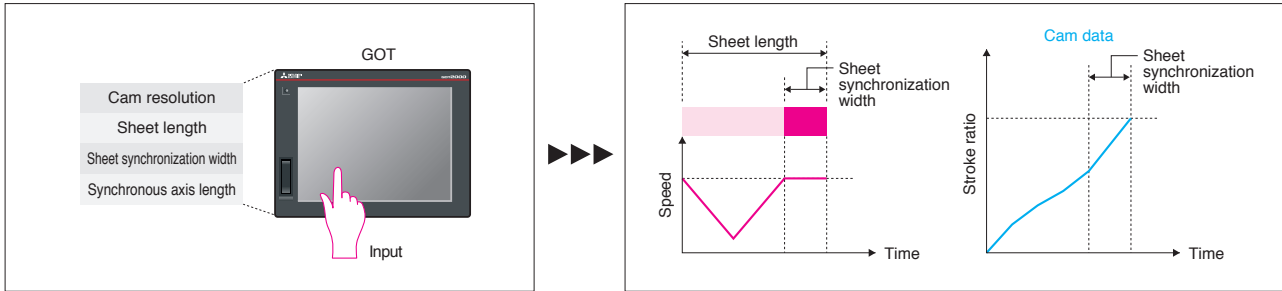

Optional Data Monitor Function

QD77MS LD77MS

The servo amplifier and servo motor information are monitored via the Simple Motion module. The information is also possible to be displayed on a user-created screen.

Setting data

Effective load ratio, Regenerative load ratio, Peak torque ratio, Load inertia ratio, Position loop gain 1, Main circuit bus voltage, Position feed back, Servo motor speed, Absolute encoder single revolution position, Power consumption, Total power consumption, etc.

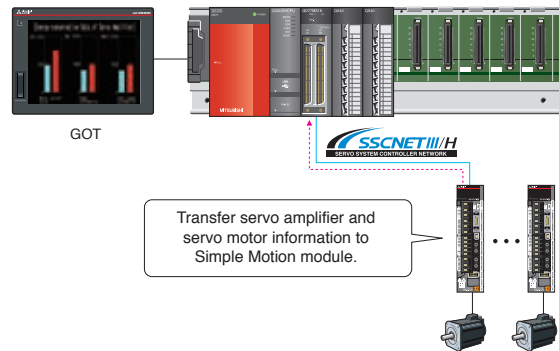

Target Position Change Function

QD77MS LD77MS
QD77GF

The target position can be changed at any time even when the products are being moved (1-axis linear control). The product is examined while being moved to the next line. If a faulty product is found, the target position is changed so that the faulty product is put in a separate tray for those rejects.

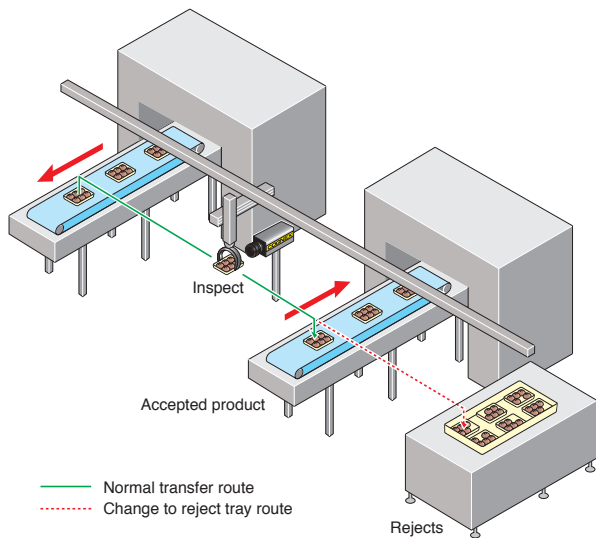

Features

Safety System

QD77MS

LD77MS

The safety system is compliant with "EN ISO13849-1:2008 Category 4 PL_e" and "EN62061 SIL CL3" (Note-1) (these standards are harmonized with European Machine Directives). Functional safety (STO, SS1, SSM, SBC, SLS) according to IEC 61800-5-2 can be achieved with a combination of MR-J4-B-RJ servo amplifier and MR-D30 functional safety unit. The safety observation function can be easily started up by setting parameters for MR-D30.

The servo amplifier with software version B3 or later supports the safety observation function.

(Note-1): STO, SS1, and SBC are compliant with the level.

IEC/EN 61800-5-2:2007 function	Safety function/level by wiring to MR-D30
STO (Safe torque off)	Category 4 PL _e , SIL 3
SS1 (Safe stop 1)	
SBC (Safe brake control)	
SLS (Safely-limited speed)	Category 3 PL _d , SIL 2
SSM (Safe speed monitor)	

[The safety signal comparison executed by MR-J4-B-RJ with MR-D30]

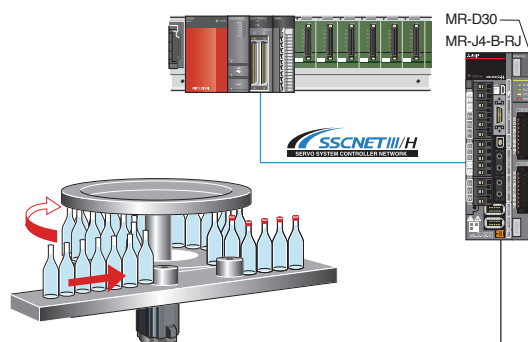
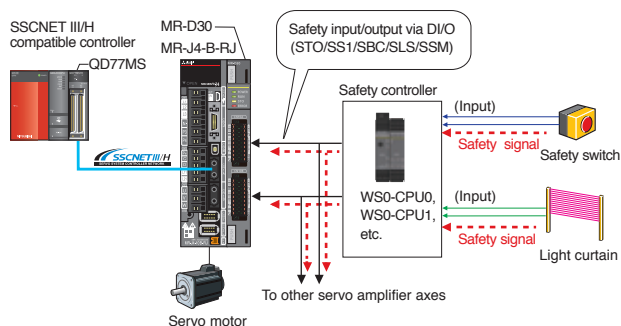

Safely-limited speed (SLS) is available without an external pulse generator.

MEMO

- Outline
- Motion Controller
- Simple Motion
- Network
- Servo Amplifier
- Engineering Environment

Simple Operation for Ease of Use

Positioning Control

QD77MS LD77MS
QD77GF

Positioning control is executed with Point table method.

- The Data Setting Assistant function simplifies the setting input process of positioning data.
- Positioning data is set more simply by using functions such as Automatic Command Speed Calculation, Offline Simulation, and automatic calculation of auxiliary arc, etc.

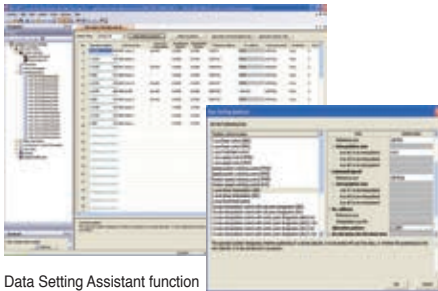

Data Setting Assistant function



Automatic Command Speed Calculation

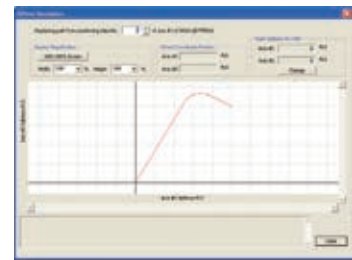

Offline Simulation

Advanced Synchronous Control

QD77MS LD77MS
QD77GF

Synchronous control can be easily achieved with software by placing mechanical modules on screen, such as the gear, shaft, speed change gear and cam.

- The Synchronous control is easily performed with parameter settings. There is no need to create complicated programs.
- Synchronous control is started/stopped on axis-by-axis basis. The synchronous control axis and positioning control axis can exist together in a program.
- The movement amount of main shaft is transmitted to the output axis via the clutch.



Synchronous Control Parameter Settings

Cam Control

QD77MS LD77MS
QD77GF

Various cam pattern can be easily created.

- Cam control has become more flexible. Various cam patterns are available.
- You can set the stroke, speed, acceleration and throb while simultaneously checking the profile on a graph.
- The created cam data are easily viewed as thumbnails.
- Cam data is imported and exported in CSV format.

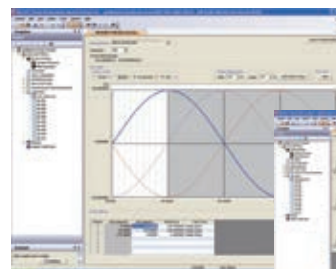

Cam Data

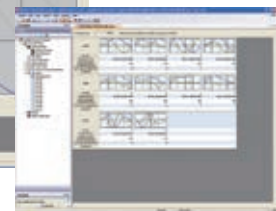

Cam Data List

Parameter Settings

QD77MS LD77MS
QD77GF

- One-point help allows parameters to be set without a manual.
- The servo amplifiers can be set easily on a graphical screen.
- The complicated electronic gear settings can be completed just by specifying the mechanical configuration (reduction ratio, ball screw pitch, etc.).



Parameter Settings



System Structure Settings



Electronic Gear Settings

Setup QD77MS LD77MS
QD77GF

Digital oscilloscope function

- Operation confirmation and troubleshooting are powerfully supported with data collection and wave displays which are synchronized to the Motion operation cycle.
- The assistant function explains all steps.
- 16CH word and 16CH bit data can be sampled. Of which, 8CH words and 8CH bits can be displayed in real time.

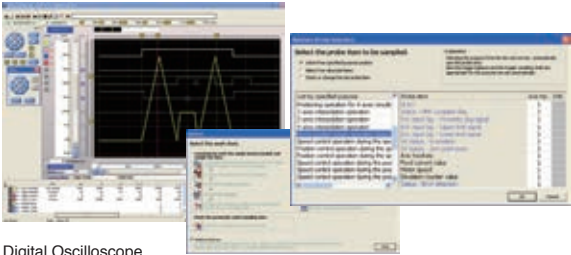

Digital Oscilloscope

Monitor and test functions

- The items needed to be displayed can be selected from various monitored information.
- The test function enables you to check basic operations without a sequence program.



Axis Monitor



Positioning Test

Adjustment of Servo Amplifier Parameters QD77MS LD77MS
QD77GF

Coordination with the MELSOFT MR Configurator2 increases the ease of servo installation. You can set and adjust servo amplifier parameters with the MELSOFT MR Configurator2, the software created with Mitsubishi servo know-how.

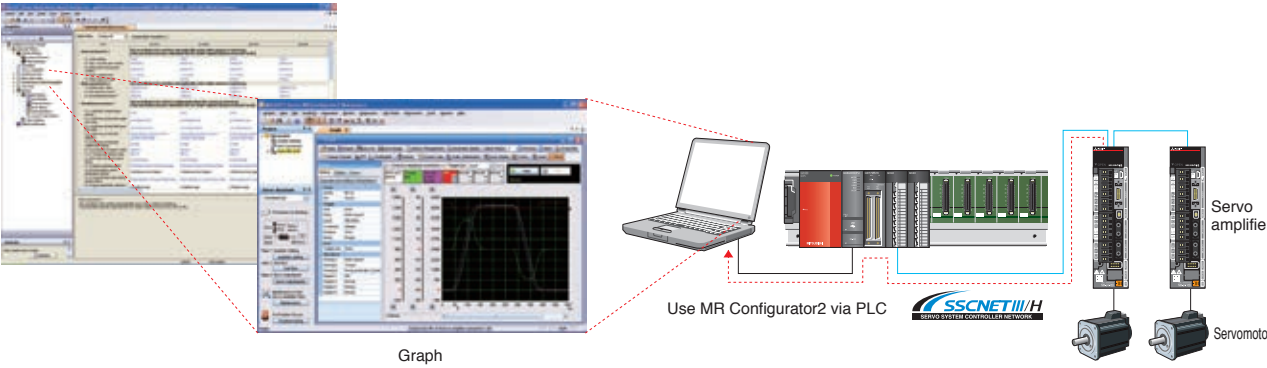

- Outline
- Motion Controller
- Simple Motion
- Network
- Servo Amplifier
- Engineering Environment

Specifications

Control specification

Item	Specifications						
	QD77MS16	QD77MS4	QD77MS2 (Note-3)	LD77MS16	LD77MS4	LD77MS2 (Note-3)	QD77GF16
Number of control axes (Virtual servo amplifier axis included)	Up to 16 axes	Up to 4 axes	Up to 2 axes	Up to 16 axes	Up to 4 axes	Up to 2 axes	Up to 16 axes
Operation cycle (Operation cycle settings) (Note-1)	0.88ms, 1.77ms						0.88ms, 1.77ms, 3.55ms
Interpolation function	Linear interpolation (Up to 4 axes), Circular interpolation (2 axes)						
Control modes	PTP (Point To Point) control, Trajectory control (both linear and arc can be set), Speed control, Speed-position switching control, Position-speed switching control, Speed-torque control						
Acceleration/deceleration process	Trapezoidal acceleration/deceleration, S-curve acceleration/deceleration						
Compensation function	Backlash compensation, Electronic gear, Near pass function						
Synchronous control	Synchronous encoder input, Cam, Phase Compensation, Cam auto-generation						
Control unit	mm, inch, degree, pulse						
Positioning data	600 data (positioning data No. 1 to 600)/axis (Can be set with MELSOFT GX Works2 or Sequence program.)						
Backup	Parameters, positioning data, and block start data can be saved on flash ROM (battery-less backup)						
OPR control	OPR method	Near-point dog method, Count method 1, Count method 2, Data set method, Scale home position signal detection method					
	Fast OPR control	Provided					
	Sub functions	OPR retry, OP shift					
Positioning control	Linear control	1-axis linear control, 2-axis linear interpolation control, 3-axis linear interpolation control, 4-axis linear interpolation control (Note-4) (Composite speed, Reference axis speed)					
	Fixed-pitch feed control	1-axis fixed-pitch feed, 2-axis fixed-pitch feed, 3-axis fixed-pitch feed, 4-axis fixed-pitch feed					
	2-axis circular interpolation	Sub point designation, center point designation					
	Speed control	1-axis speed control, 2-axis speed control, 3-axis speed control, 4-axis speed control					
	Speed-position switching control	INC mode, ABS mode					
	Position-speed switching control	INC mode					
	Current value change	Positioning data, Start No. for a current value changing					
	NOP instruction	Provided					
	JUMP instruction	Unconditional JUMP, Conditional JUMP					
LOOP, LEND	Provided						
High-level positioning control	Block start, Condition start, Wait start, Simultaneous start, Repeated start						
Manual control	JOG operation	Provided					
	Inching operation	Provided					
	Manual pulse generator operation	Possible to connect 1 module (Incremental) Unit magnification (1 to 10000 times)					
Expansion control	Speed-torque control	Speed control without positioning loops, Torque control, Tightening & press-fit control (Note-5)					
Absolute position system	Made compatible by setting battery to servo amplifier						
Synchronous encoder interface	Up to 4 channels (Total of the internal interface, via PLC CPU interface, and servo amplifier interface (Note-5))						
Functions that limit control	Internal interface	1 channel (Incremental)					
	Speed limit function	Speed limit value, JOG speed limit value					
	Torque limit function	Torque limit value_same setting, torque limit value_individual setting					
	Forced stop	Valid/Invalid setting					
	Software stroke limit function	Movable range check with current feed value, movable range check with machine feed value					
Functions that change control details	Hardware stroke limit function	Provided					
	Speed change function	Provided					
	Override function	Provided					
	Acceleration/deceleration time change function	Provided					
	Torque change function	Provided					
Other functions	Target position change function	Target position address and speed to target position are changeable					
	M code output function	Provided					
	Step function	Deceleration unit step, Data No. unit step					
	Skip function	Via PLC CPU, Via external command signal					
Mark detection function	Teaching function	Provided					
	Mark detection signal	4 points	2 points	4 points	2 points	4 points	
	Mark detection setting	16 settings	4 settings	16 settings	4 settings	16 settings	
Optional data monitor function	4 points/axis						—
Driver communication function	Provided						—
Amplifier-less operation function	Provided						—
Digital oscilloscope function (Note-2)	Bit data	16ch	8ch	16ch	8ch	16ch	
	Word data	16ch	4ch	16ch	4ch	16ch	

(Note-1): Default value is 1.77 ms. If necessary, check the operation time and change to 0.88 ms.

(Note-2): 8CH word data and 8CH bit data can be displayed in real time.

(Note-3): The maximum number of control axes for QD77MS2 and LD77MS2 is two axes. Use QD77MS4, QD77MS16, LD77MS4, or LD77MS16 to control three or more axes.

(Note-4): 4-axis linear interpolation control is enabled only at the reference axis speed.

(Note-5): QD77MS and LD77MS only.

■ Synchronous control specification

Synchronous control

Item		Number of settable axes						
		QD77MS16	QD77MS4	QD77MS2	LD77MS16	LD77MS4	LD77MS2	QD77GF16
Input axis	Servo input axis	16 axes/module	4 axes/module	2 axes/module	16 axes/module	4 axes/module	2 axes/module	16 axes/module
	Synchronous encoder axis	4 axes/module						
Composite main shaft gear		1/output axis						
Main shaft main input axis		1/output axis						
Main shaft sub input axis		1/output axis						
Main shaft gear		1/output axis						
Main shaft clutch		1/output axis						
Auxiliary shaft		1/output axis						
Auxiliary shaft gear		1/output axis						
Auxiliary shaft clutch		1/output axis						
Auxiliary shaft composite gear		1/output axis						
Speed change gear		1/output axis						
Output axis (Cam axis)		16 axes/module	4 axes/module	2 axes/module	16 axes/module	4 axes/module	2 axes/module	16 axes/module

Cam control

Item			Specifications						
			QD77MS16	QD77MS4	QD77MS2	LD77MS16	LD77MS4	LD77MS2	QD77GF16
Memory capacity	Storage area for cam data		256k bytes						
	Working area for cam data		1024k bytes						
Number of registration			Max. 256 (depending on memory capacity, cam resolution and number of coordinates)						
Comment			Up to 32 characters for each cam data						
Cam data	Stroke ratio data type	Cam resolution	256, 512, 1024, 2048, 4096, 8192, 16384, 32768						
		Stroke ratio	-214.7483648 to 214.7483647 [%]						
	Coordinate data type	Coordinate number	2 to 16384						
		Coordinate data	Input value: 0 to 2147483647 Output value: -2147483648 to 2147483647						
Cam auto-generation			Cam auto-generation for rotary cutter						

Specifications

Module specification

Simple Motion module QD77MS16/QD77MS4/QD77MS2



Item		Specifications		
		QD77MS16	QD77MS4	QD77MS2
Number of control axes (Virtual servo amplifier axis included)		Up to 16 axes	Up to 4 axes	Up to 2 axes
Servo amplifier connection system		SSCNET III/H		
Maximum overall cable distance [m(ft.)]		SSCNET III/H: 1600 (5249.34), SSCNET III: 800 (2624.67)		
Maximum distance between stations [m(ft.)]		SSCNET III/H: 100 (328.08), SSCNET III: 50 (164.04)		
Peripheral I/F		Via CPU module (USB, RS-232, Ethernet)		
Manual pulse generator operation function		Possible to connect 1 module		
Synchronous encoder operation function		Possible to connect 4 modules (Total of the internal interface, via PLC CPU interface, and servo amplifier interface)		
Near-point dog signal (DOG) External command signal/ Switching signal (CHG)	Number of input points	4 points		2 points
	Input method	Positive common/ Negative common shared (Photocoupler isolation)		
	Rated input voltage/current	24 VDC/ Approx. 5 mA		
	Operating voltage range	19.2 to 26.4 VDC (24 VDC +10%/-20%, ripple ratio 5% or less)		
	ON voltage/current	17.5 VDC or more/ 3.5 mA or more		
	OFF voltage/current	7 VDC or less/ 1.0 mA or less		
	Input resistance	Approx 6.8 kΩ		
Forced stop input signal (EMI) Upper limit signal (FLS) Lower limit signal (RLS) Stop signal (STOP)	Response time	1 ms or less (OFF→ON, ON→OFF)		
	Recommended wire size	AWG24 (0.2 mm ²)		
	Number of input points	4 points, 1 point (EMI)		2 points, 1 point (EMI)
	Input method	Positive common/ Negative common shared (Photocoupler isolation)		
	Rated input voltage/current	24 VDC/ Approx. 5 mA		
	Operating voltage range	19.2 to 26.4VDC (24VDC +10%/-20%, ripple ratio 5% or less)		
	ON voltage/current	17.5 VDC or more/ 3.5 mA or more		
Manual pulse generator/ Incremental synchronous encoder signal	OFF voltage/current	7 VDC or less/ 1.0 mA or less		
	Input resistance	Approx 6.8 kΩ		
	Response time	4 ms or less (OFF→ON, ON→OFF)		
	Recommended wire size	AWG24 (0.2 mm ²)		
	Signal input form	Phase A/Phase B (magnification by 4/magnification by 2/magnification by 1), PULSE/SIGN		
	Input frequency	1Mpps (After magnification by 4, up to 4 Mpps) (Differential output type) 200 kpps (After magnification by 4, up to 800 kpps) (Voltage-output/Open-collector type)		
	Cable length	Up to 30 m (98.43ft.) (Differential output type) Up to 10 m (32.81ft.) (Voltage-output/Open-collector type)		
Number of I/O occupying points	32 points (I/O allocation: Intelligent function module, 32 points)			
Number of module occupied slots	1			
5VDC internal current consumption [A]	0.75	0.6		
Mass [kg]	0.16		0.15	
Exterior dimensions [mm(inch)]	98.0 (3.86) (H) × 27.4 (1.08) (W) × 90.0 (3.54) (D)			

Applicable system

Basic Model QCPU	Q00JCPU, Q00CPU, Q01CPU
High performance model QCPU	Q02CPU, Q02HCPU, Q06HCPU, Q12HCPU, Q25HCPU
Universal model QCPU	Q00UJCPU, Q00UCPU, Q01UCPU, Q02UCPU, Q03UDCPU, Q04UDHCPU, Q06UDHCPU, Q10UDHCPU, Q13UDHCPU, Q20UDHCPU, Q26UDHCPU, Q03UDECPU, Q04UDEHCPU, Q06UDEHCPU, Q10UDEHCPU, Q13UDEHCPU, Q20UDEHCPU, Q26UDEHCPU, Q50UDEHCPU, Q100UDEHCPU
High-speed universal model QCPU	Q03UDVCPU, Q04UDVCPU, Q06UDVCPU, Q13UDVCPU, Q26UDVCPU
C Controller	Q12DCCPU-V, Q24DHCCPU-V, Q24DHCPU-LS

Simple Motion module LD77MS16/LD77MS4/LD77MS2



Item		Specifications		
		LD77MS16	LD77MS4	LD77MS2
Number of control axes (Virtual servo amplifier axis included)		Up to 16 axes	Up to 4 axes	Up to 2 axes
Servo amplifier connection system		SSCNET III/H (1 system)		
Maximum distance between stations [m(ft.)]		SSCNET III/H: 1600 (5249.34), SSCNET III: 800 (2624.67)		
Maximum distance between stations [m(ft.)]		SSCNET III/H: 100 (328.08), SSCNET III: 50 (164.04)		
Peripheral I/F		Via CPU module (USB, Ethernet)		
External command signal/ Switching signal (CHG)	Number of input points	4 points		2 points
	Input method	Positive common/Negative common shared (Photocoupler isolation)		
	Rated input voltage/current	24 VDC/Approx. 5 mA		
	Operating voltage range	21.6 to 26.4 VDC (24 VDC $\pm 10\%$, ripple ratio 5 % or less)		
	ON voltage/current	17.5 VDC or more/3.5 mA or more		
	OFF voltage/current	5 VDC or less/0.9 mA or less		
	Input resistance	Approx. 5.6 k Ω		
	Response time	1 ms or less (OFF \rightarrow ON, ON \rightarrow OFF)		
Forced stop input signal (EMI)	Recommended wire size	AWG24 (0.2 mm ²)		
	Number of input points	1 point (EMI)		
	Input method	Positive common/Negative common shared (Photocoupler isolation)		
	Rated input voltage/current	24 VDC/Approx. 2.4 mA		
	Operating voltage range	20.4 to 26.4 VDC (24 VDC +10 %/-15 %, ripple ratio 5 % or less)		
	ON voltage/current	17.5 VDC or more/2.0 mA or more		
	OFF voltage/current	1.8 VDC or less/0.18 mA or less		
	Input resistance	Approx. 10 k Ω		
Manual pulse generator/ Incremental synchronous encoder signal	Response time	1 ms or less (OFF \rightarrow ON, ON \rightarrow OFF)		
	Recommended wire size	AWG24 (0.2mm ²)		
	Signal input form	Phase A/Phase B (magnification by 4/magnification by 2/magnification by 1), PULSE/SIGN		
Cable length	Input frequency	1Mpps (After magnification by 4, up to 4 Mpps) (Differential output type) 200 kpps (After magnification by 4, up to 800 kpps) (Voltage-output/Open-collector type)		
		Up to 30 m (98.43ft.) (Differential output type) Up to 10 m (32.81ft.) (Voltage-output/Open-collector type)		
Number of I/O occupying points		32 points (I/O allocation: Intelligent function module, 32 points)		
Number of module occupied slots		2		
5VDC internal current consumption [A]		0.7	0.55	
Mass [kg]		0.22		
Exterior dimensions [mm(inch)]		90.0 (3.54) (H) \times 45.0 (1.77) (W) \times 95.0 (3.74) (D)		

Applicable system

MELSEC-L series CPU	LO25CPU, LO2CPU, LO2CPU-P, LO6CPU, L26CPU, L26CPU-BT, L26CPU-PBT
---------------------	--

Specifications

Simple Motion module QD77GF16



Item		Specifications
		QD77GF16
Number of control axes (Virtual servo amplifier axis included)		Up to 16 axes
Servo amplifier connection system		CC-Link IE Field Network
Maximum distance between stations [m(ft.)]		100 (328.08)
Peripheral I/F		Via CPU module (USB, RS-232, Ethernet)
Manual pulse generator operation function		Possible to connect 1 module
External command signal	Number of input points	4 points
	Input method	Positive common/ Negative common shared (Photocoupler isolation)
	Rated input voltage/current	24 VDC/ Approx. 5 mA
	Operating voltage range	21.6 to 26.4 VDC (24 VDC \pm 10%, ripple ratio 5% or less)
	ON voltage/current	17.5 VDC or more/ 3.5 mA or more
	OFF voltage/current	5 VDC or less/ 0.9 mA or less
	Input resistance	Approx 5.6 k Ω
	Response time	1 ms or less (OFF \rightarrow ON, ON \rightarrow OFF)
Recommended wire size		AWG24 (0.2 mm ²)
Forced stop input signal (EMI)	Number of input points	1 point
	Input method	Positive common/ Negative common shared (Photocoupler isolation)
	Rated input voltage/current	24 VDC/ Approx. 2.4 mA
	Operating voltage range	20.4 to 26.4VDC (24VDC +10%/-15%, ripple ratio 5% or less)
	ON voltage/current	17.5 VDC or more/ 2 mA or more
	OFF voltage/current	1.8 VDC or less/ 0.18 mA or less
	Input resistance	Approx. 10 k Ω
	Response time	1 ms or less (OFF \rightarrow ON, ON \rightarrow OFF)
Recommended wire size		AWG24 (0.2 mm ²)
Manual pulse generator/Incremental synchronous encoder signal	Signal input form	Phase A/Phase B (magnification by 4/magnification by 2/magnification by 1), PULSE/SIGN
	Input frequency	1Mpps (After magnification by 4, up to 4 Mpps) (Differential output type) 200 kpps (After magnification by 4, up to 800 kpps) (Voltage-output/Open-collector type)
	Cable length	Up to 30 m (98.43ft.) (Differential output type) Up to 10 m (32.81ft.) (Voltage-output/Open-collector type)
Number of I/O occupying points		32 points (I/O allocation: Intelligent function module, 32 points)
Number of module occupied slots		1
5VDC internal current consumption [A]		0.8
Mass [kg]		0.26
Exterior dimensions [mm(inch)]		98.0 (3.86) (H) \times 27.4 (1.08) (W) \times 115 (4.53) (D)

Applicable system

Universal model QCPU (Upper five digit of Serial No. is "12012" or later)	Q00UJCPU, Q00UCPU, Q01UCPU, Q02UCPU, Q03UDCPU, Q04UDHCPU, Q06UDHCPU, Q10UDHCPU, Q13UDHCPU, Q20UDHCPU, Q26UDHCPU, Q03UDECPU, Q04UDEHCPU, Q06UDEHCPU, Q10UDEHCPU, Q13UDEHCPU, Q20UDEHCPU, Q26UDEHCPU, Q50UDEHCPU, Q100UDEHCPU
High-speed universal model QCPU	Q03UDVCPU, Q04UDVCPU, Q06UDVCPU, Q13UDVCPU, Q26UDVCPU

Performance specification of CC-Link IE Field Network (QD77GF)

Item		Specifications
		Motion station
Maximum number of links per network	RX	8k points (8192 points, 1k bytes)
	RY	8k points (8192 points, 1k bytes)
	RWr	1k points (1024 points, 2k bytes)
	RWw	1k points (1024 points, 2k bytes)
Maximum number of link per station	RX	8k points (8192 points, 1k bytes)
	RY	8k points (8192 points, 1k bytes)
	RWr	1k points (1024 points, 2k bytes)
	RWw	1k points (1024 points, 2k bytes)
Communication speed		1Gbps
Maximum number of stations per network	I/O devices	105 (1 master plus 104 slave stations)
	Servo amplifier	16
Connectable station type	Local station	Unable to connect
	Intelligent device station	Able to connect
	Remote device station	Able to connect
	Remote I/O station	Able to connect
Cable type		Ethernet cable (Category 5e or higher)
Overall cable distance (max.)	Line topology	12000m (with 1 master plus 120 slaves connected)
	Star topology	Depends on the system configuration
Station-to-station distance (max.)		100m
Maximum number of networks		239
Topology		Line, star ^(Note-1) , and line/star mixed topologies ^(Note-1)
Synchronous communication		Available

(Note-1): Star topology needs a HUB. HUB applied: DT135TX (Produced by Mitsubishi Electric System & Service Co., Ltd.)

Cable specifications (QD77GF)

Item		Specifications
Ethernet cable		Category 5e or higher, (Double shielded/STP) Straight cable
	Standard	The following conditioning cables: <ul style="list-style-type: none"> • IEEE802.3 (1000BASE-T) • ANSI/TIA/EIA-568-B (Category 5e)
	Connector	RJ-45 connector with shield

(Note): Use the cables recommended by CC-Link Partner Association for CC-Link IE Field Network.
 CC-Link IE Field Network cables are not compatible with CC-Link IE Controller Network.
 The cable for CC-Link IE Field Network cable is produced by Mitsubishi Electric System & Service Co., Ltd.
 For details of Mitsubishi Electric System & Service Co., Ltd. products, contact us by sending an e-mail to the following address.
 [Sales office] FA PRODUCT DIVISION mail: osb.webmaster@melsc.jp

Simple Motion Module

Specifications

Exterior dimensions

Simple Motion module QD77MS16

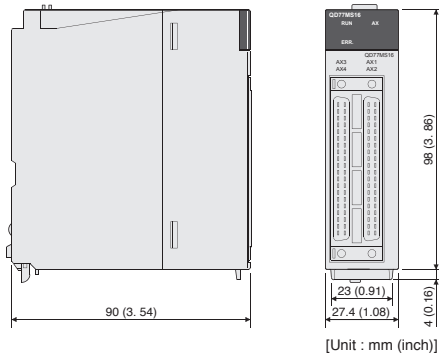

Simple Motion module QD77MS4

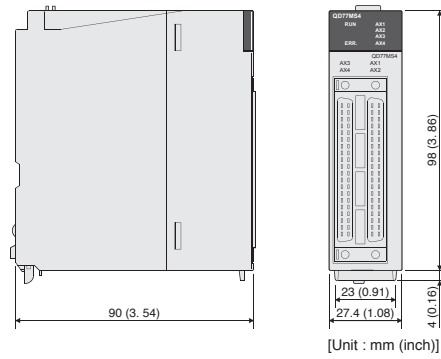

Simple Motion module QD77MS2

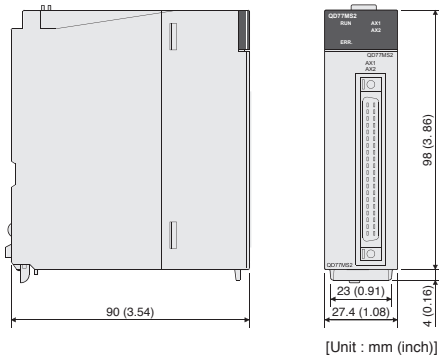

Simple Motion module QD77GF16

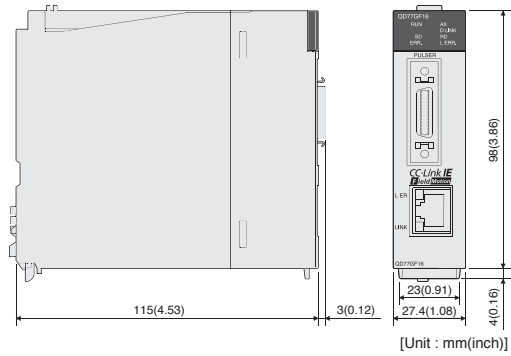

Simple Motion module LD77MS16

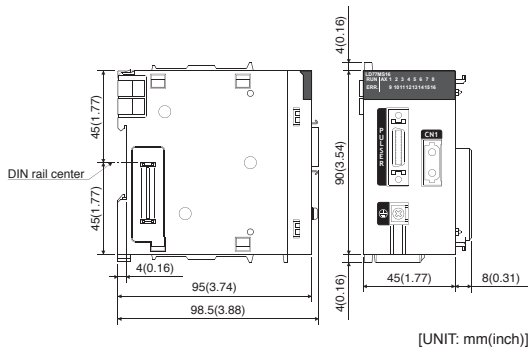

Simple Motion module LD77MS4

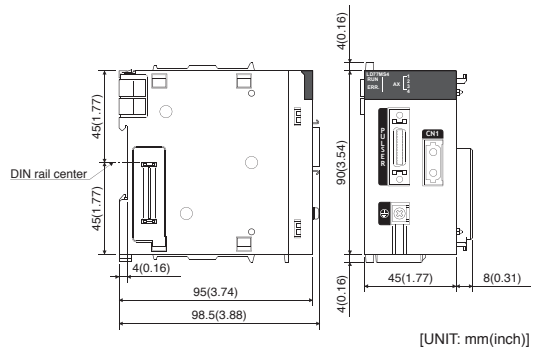

Simple Motion module LD77MS2

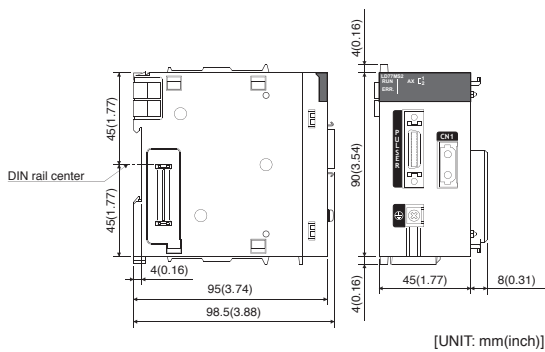

■ Component

Simple Motion module QD77MS/LD77MS/QD77GF

[Simple Motion dedicated module]

Part	Model	Description		Standards	
Simple Motion Module	QD77MS16 ^(Note-1)	Up to 16 axes		CE, UL, KC	
	QD77MS4 ^(Note-1)	Up to 4 axes		CE, UL, KC	
	QD77MS2 ^(Note-1)	Up to 2 axes		CE, UL, KC	
	LD77MS16 ^(Note-2)	Up to 16 axes		CE, UL, KC	
	LD77MS4 ^(Note-2)	Up to 4 axes		CE, UL, KC	
	LD77MS2 ^(Note-2)	Up to 2 axes		CE, UL, KC	
	QD77GF16 ^(Note-2)	Up to 16 axes		CE, UL, KC	
SSCNETIII cable ^(Note-3)	MR-J3BUS_M	· Simple Motion module ⇔MR-J4-B · MR-J4-B⇔MR-J4-B	Standard code for inside panel	0.15m (0.49ft.), 0.3m (0.98ft.), 0.5m (1.64ft.), 1m (3.28ft.), 3m (9.84ft)	—
	MR-J3BUS_M-A		Standard code for outside panel	5m (16.40ft.), 10m (32.81ft.), 20m (65.62ft)	—
	MR-J3BUS_M-B ^(Note-4)		Long distance cable	30m (98.43ft.), 40m (131.23ft.), 50m (164.04ft.)	—
Manual pulse generator	MR-HDP01	Number of pulses per revolution: 25pulse/rev (100pulse/rev after magnification by 4), Permitted speed: 200r/min (Normal rotation)		—	
Connector for external input signal cable	LD77MHIOCON	Manual pulse generator/Incremental synchronous encoder interface, Interface for forced stop input, External command signal/Switching signal interface		—	

(Note-1): Order the A6CON1, A6CON2, and A6CON4 separately because the connectors are not included in the package.

(Note-2): Order the LD77MHIOCON separately because the connector is not included in the package.

(Note-3): "_" indicates cable length (015: 0.15m (0.49ft.), 03: 0.3m (0.98ft.), 05: 0.5m (1.64ft.), 1: 1m (3.28ft.), 3: 3m (9.84ft.), 5: 5m (16.40ft.), 10: 10m (32.81ft.), 20: 20m (65.62ft.), 30: 30m (98.43ft.), 40: 40m (131.23ft.), 50: 50m (164.04ft))

(Note-4): For long distance cable up to 100m (328.08ft.) and ultra-long bending life cable, contact Mitsubishi Electric System & Service Co., Ltd.
[Sales office] FA PRODUCT DIVISION mail: osb.webmaster@melsc.jp

SSCNET III/H

SERVO SYSTEM CONTROLLER NETWORK

The blazingly fast

High-response System Achieved with SSCNET III/H

Three Times Faster Communication Speed

Industry-leading levels

Communication speed is increased to 150 Mbps full duplex (equivalent to 300 Mbps half duplex), three times faster than the conventional speed. System response is dramatically improved.

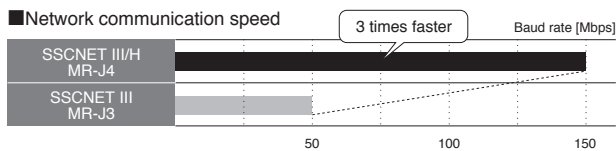

Cycle Times as Fast as 0.22 ms

Industry-leading levels

Smooth control of machine is possible using high-speed serial communication with cycle times of 0.22 ms.

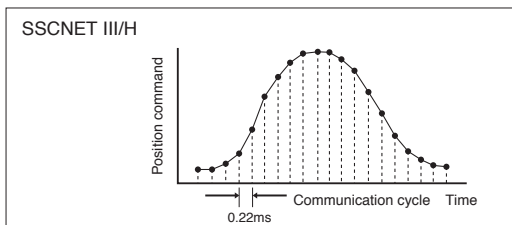
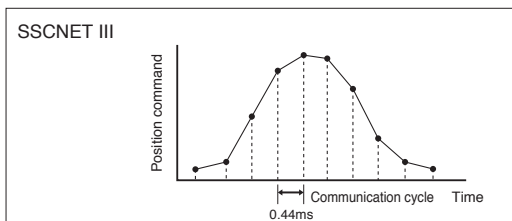

Deterministic and Synchronized Communication

Complete deterministic and synchronized communication is achieved with SSCNET III/H, offering technical advantages in machines such as printing and food processing machines that require synchronous accuracy.

Timing of servo amplifier processing

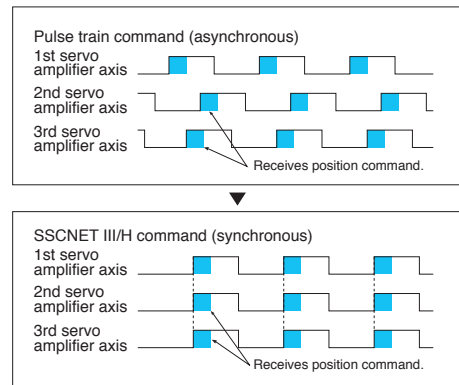

No Transmission Collision

The fiber-optic cables thoroughly shut out noise that enters from the power cable or external devices. Noise tolerance is dramatically improved as compared to metal cables.

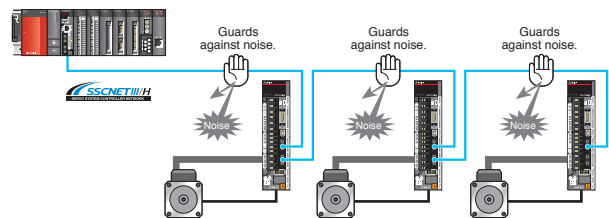

speed and response of 150 Mbps full-duplex baud rate SSCNET III/H optical networking

Outline

Motion Controller

Simple Motion

Network

Servo Amplifier

Engineering Environment

Dramatically Reduced Wiring

The SSCNET III/H Head module allows the controller to connect remotely with various modules (I/O, analog, high-speed counter, etc.) via SSCNET III/H. This results in reduced wiring since the Motion controller receives the I/O and analog I/O signals directly from the servo amplifier side.

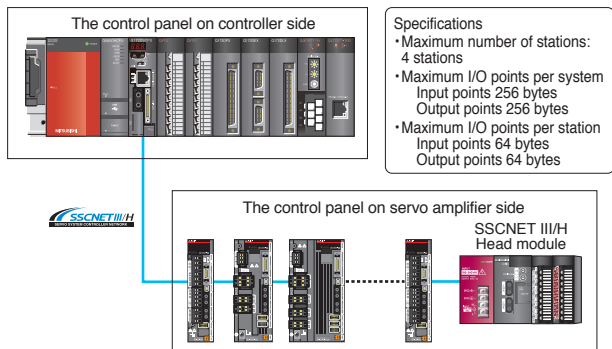

Long Distance Wiring up to 1600 m (5249.34 ft.)

Enhanced performance

Long distance wiring is possible up to 1600 m (5249.34 ft.) per system (maximum of 100 m (328.08 ft.) between stations × 16 axes). Thus, it is suitable for large-scale systems.

* This is when all axes are connected via SSCNET III/H.

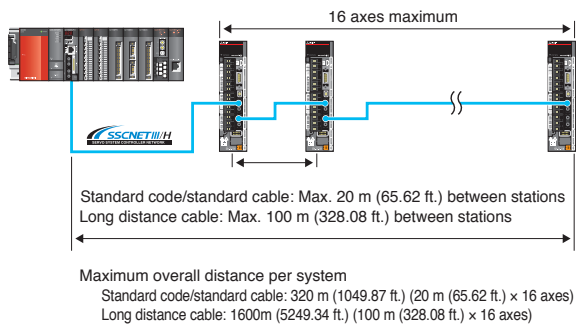

Central Control with Network

Large amounts of servo data are exchanged in real-time between the controller and the servo amplifier. Using MELSOFT MR Configurator2 on a personal computer that is connected to the Motion controller or the Simple Motion module helps consolidate information such as parameter settings and monitoring for the multiple servo amplifiers.

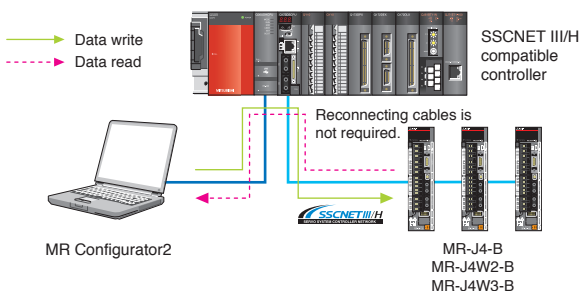

SSCNET III/H Compatible and SSCNET III Compatible Products Connected in a Same System

SSCNET III/H and SSCNET III compatible controllers support the use of SSCNET III/H and SSCNET III compatible servo amplifiers together in a same system.

* When the SSCNET III compatible products are in the system, the communication speed is 50 Mbps, and the function and the performance are equivalent to those of MR-J3.

Communication speed: 150 Mbps

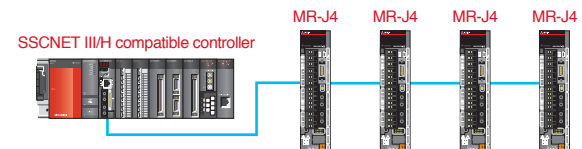

Communication speed: 50 Mbps

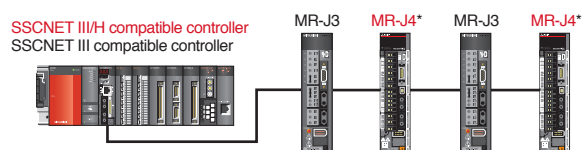

CC-Link IE Field Network

CC-Link IE Field Network — All-rounder network opens up new areas of control

All-rounder Network

CC-Link IE Field Network is an Ethernet-based open network. Its highly flexible wiring to match your device layout can perform high-speed controller distributed control, I/O control and safety control. Because the CC-Link IE Field Network is based on the Ethernet, cables and connectors are highly available in the world.

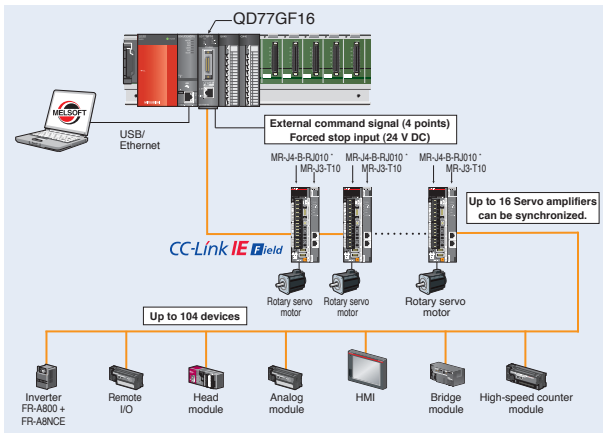

Motion Control Achieved

CC-Link IE Field Network is now equipped with Motion function. High-speed positioning control, synchronous control and cam control can be performed easily at a control cycle of 0.88 ms, 1.77 ms, or 3.55 ms just with simple parameter settings and startup from the sequence program. This network is suitable for food processing machines and machine tools which require synchronous control.

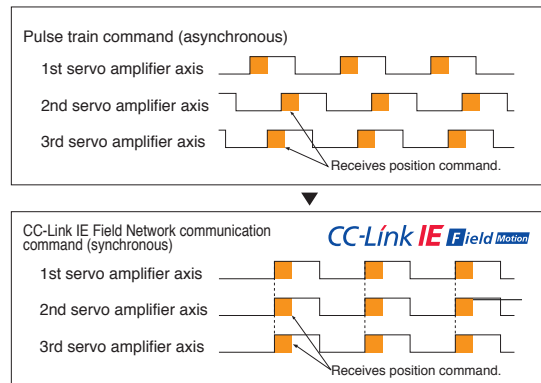

Flexible Network Topology

Line, star, and line/star mixed topologies are available for the CC-Link IE Field Network wiring layout.

Line/star mixed topology

Star topology is available using an industrial switching HUB. HUB applied: DT135TX (manufactured by Mitsubishi Electric System & Service Co., Ltd.)

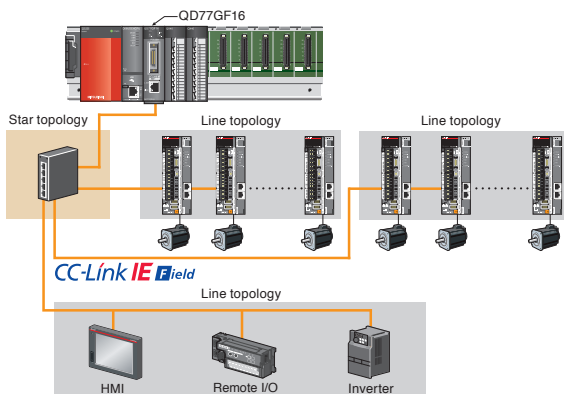

Line topology

The Simple Motion modules (Master station) can be connected to slave devices without using a HUB, which reduces cost.

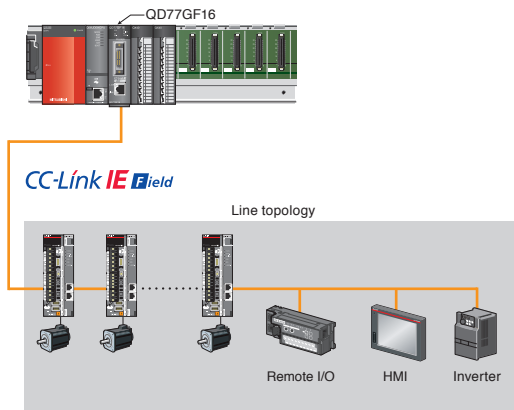

FA Integrated Network

FA integrated network for optimal FA environment

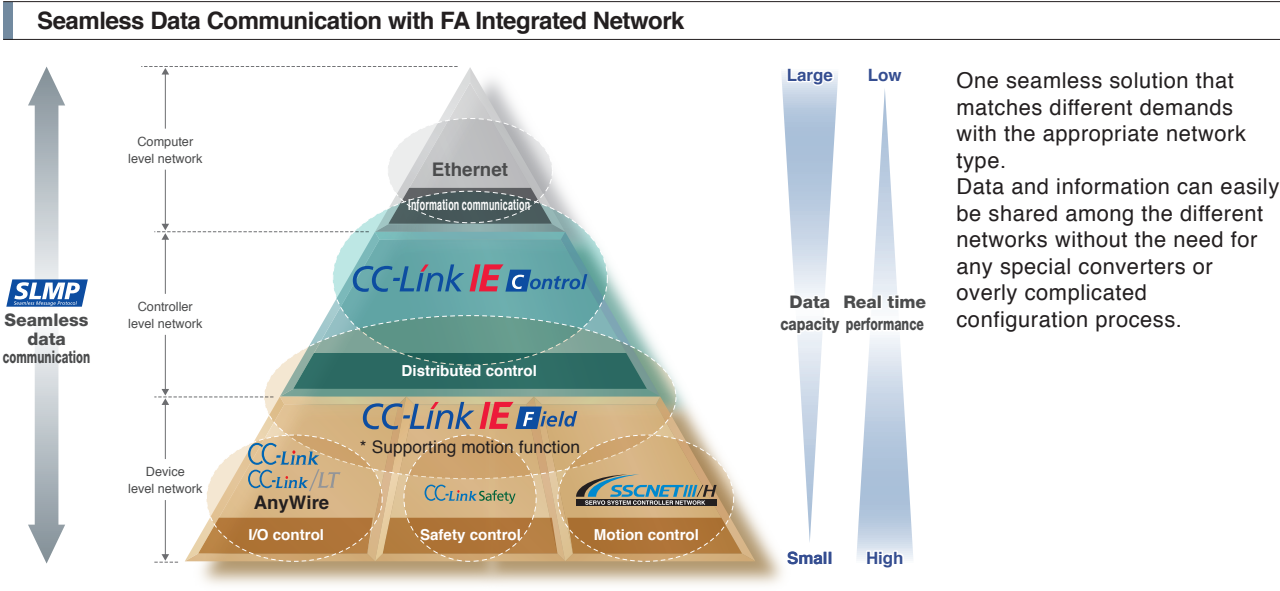

FA Integrated Network System Architecture

Connections and accesses to various devices are possible through CC-link IE Control, the controller network; CC-Link IE Field, the field network; and SSCNET III/H, the Motion network; and Anywire, the sensor network. The network wiring layout is highly flexible to best fit the needs of the application.

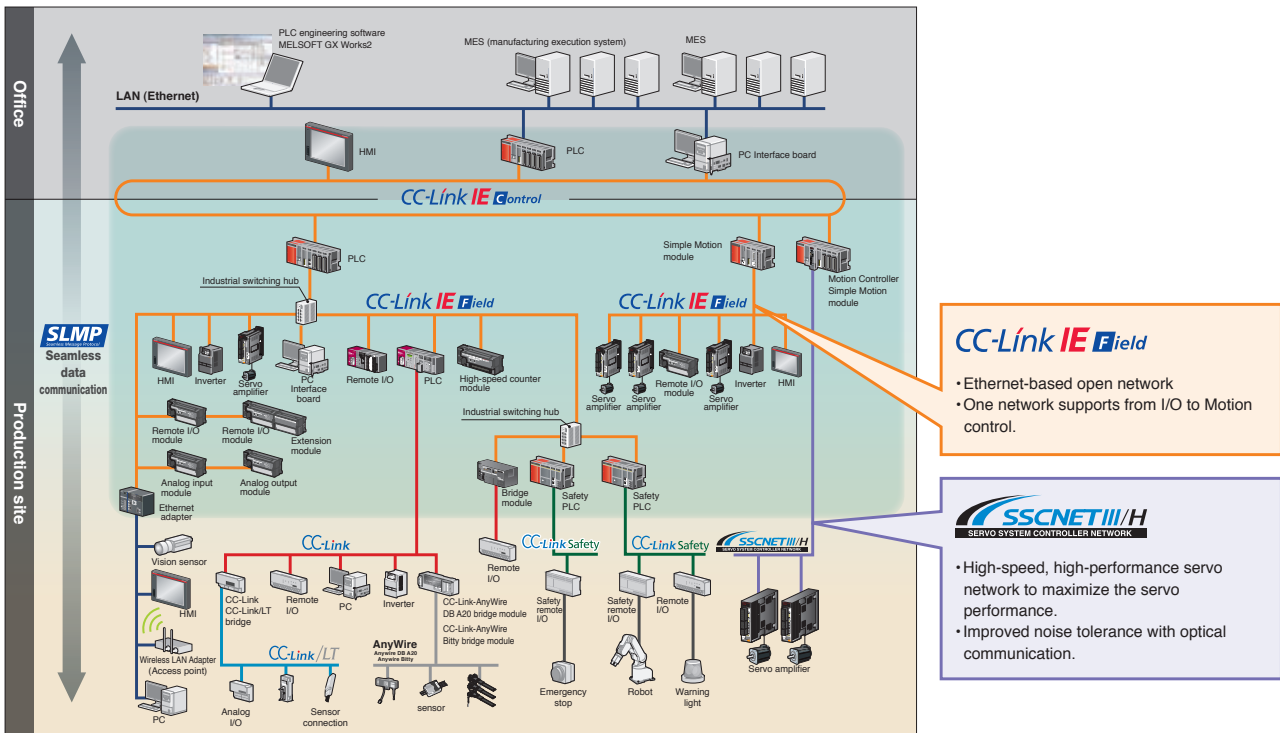

Outline

Motion Controller

Simple Motion

Network

Servo Amplifier

Engineering Environment

Servos in harmony with man, machine and the environment



Servo Amplifier

Compatible with the advanced high-speed Motion network "SSCNET III/H", these servo amplifiers operate rotary/linear servo motors or direct drive motors as standard ^(Note). Multi-axis servo amplifiers are also available, achieving energy conservation, space-saving, and reduced wiring.

(Note): MR-J4-B-RJ010 servo amplifiers are compatible only with rotary servo motors.



SSCNET III/H compatible servo amplifier
MR-J4-B
MR-J4-B-RJ



SSCNET III/H compatible 2-axis servo amplifier
MR-J4W2-B



SSCNET III/H compatible 3-axis servo amplifier
MR-J4W3-B



CC-Link IE Field Network servo amplifier with Motion
MR-J4-B-RJ010
+MR-J3-T10

Servo Motor

A variety of models are available to match various applications. These include rotary servo motors for high-torque output during high speed, linear servo motors for highly accurate tandem synchronous control, and direct drive motors for compact and rigid machine, and high-torque operations.

Rotary servo motor



Small capacity, low inertia
HG-KR series
Capacity: 50 to 750 W



Small capacity, ultra-low inertia
HG-MR series
Capacity: 50 to 750 W



Medium capacity, medium inertia
HG-SR series
Capacity: 0.5 to 7 kW



Medium/large capacity, low inertia
HG-JR series
Capacity: 0.5 to 55 kW



Medium capacity, ultra-low inertia
HG-RR series
Capacity: 1 to 5 kW



Medium capacity, flat type
HG-UR series
Capacity: 0.75 to 5 kW

Linear servo motor



Core type
LM-H3 series
Rating: 70 to 960 N



Core type (natural/liquid cooling)
LM-F series
Rating: 300 to 3000 N (natural cooling)
Rating: 600 to 6000 N (liquid cooling)



Core type with magnetic attraction counter-force
LM-K2 series
Rating: 120 to 2400 N



Coreless type
LM-U2 series
Rating: 50 to 800 N



TM-RFM series
Rating: 2 to 240 N·m

Direct drive motor

Machine

Industry-leading Level of Servo Amplifier Basic Performance

Industry-leading levels

Our original high-speed servo control architecture is evolved from the conventional two-degrees-of-freedom model adaptive control and applied to the dedicated execution engine. **Speed frequency response is increased to 2.5 kHz.** Compatible servo motors are equipped with a **high-resolution absolute position encoder of 4,194,304 pulses/rev (22-bit)**, enabling high-speed and high-accuracy operation. The performance of the high-end machine is utilized to the fullest.

[Settling time comparison with the prior model]

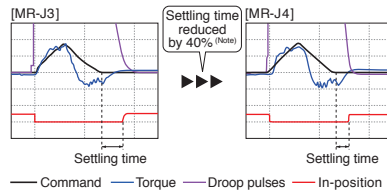

(Note): The result is based on our evaluation condition.

[Dedicated execution engine]

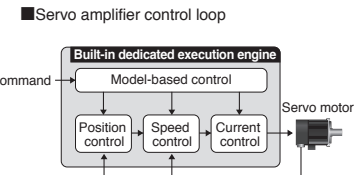

Improving Machine Performance with High-performance Servo Motors

Industry-leading levels

Rotary servo motors achieve high-accuracy positioning and smooth rotation with a high-resolution encoder and improved processing speed.

[Resolution comparison with the prior model]

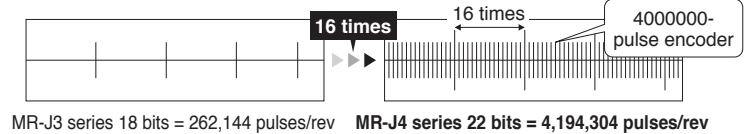

Advanced One-touch Tuning Function

Enhanced functions

Servo gain adjustment is complete just by turning on the one-touch tuning function. With this function, machine resonance filter, advanced vibration suppression control II (Note), and robust filter are automatically adjusted to maximize your machine performance. This function also sets responsiveness automatically while the real-time auto tuning requires manual setting.

(Note): The advanced vibration suppression control II automatically adjusts one frequency.

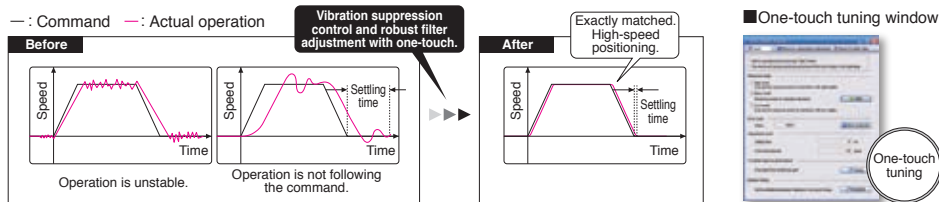

Advanced Vibration Suppression Control II

Patent pending Enhanced functions

The advanced vibration suppression control II suppresses two types of low frequency vibrations owing to vibration suppression algorithm which supports three-inertia system. This function is effective in suppressing residual vibration with relatively low frequency of approximately 100 Hz or less generated at the end of an arm and in a machine, enabling a shorter settling time. Adjustment is easily performed on MR Configurator2.

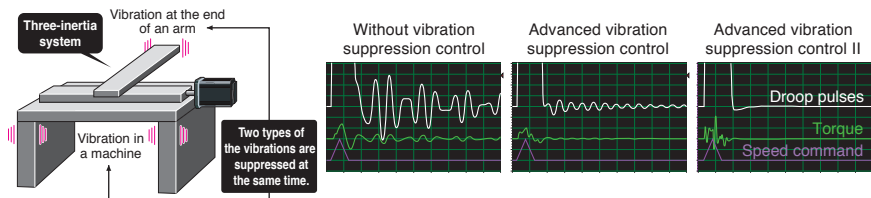

Application examples

[Pick and place robots] [Automatic assembly equipment] [Material handling systems]

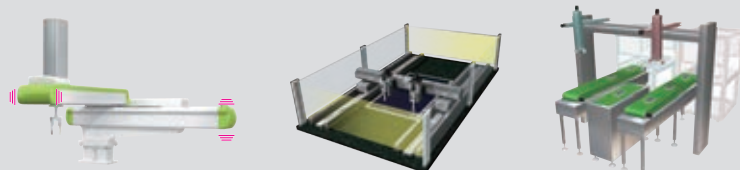

Outline

Motion Controller

Simple Motion

Network

Servo Amplifier

Engineering Environment

Man

Functions According to IEC/EN 61800-5-2

STO (Safe torque off) and SS1^(Note-1) (Safe stop 1) are integrated as standard, enabling the safety system to be configured easily in the machine. (SIL 2)

- Turning off the control power of servo amplifier is not required, cutting out the time for restart. Additionally, home position return is not required.
- Magnetic contactor for preventing unexpected motor start is not required.^(Note-2)

(Note-1): Safety equipment (MR-J3-D05, safety programmable controller MELSEC QS/WS series, etc.) is required.
(Note-2): MR-J4 series servo amplifiers do not require a magnetic contactor to satisfy the requirements of STO; however, the figure shows a magnetic contactor installed to prevent servo alarms and a risk of electric shock.

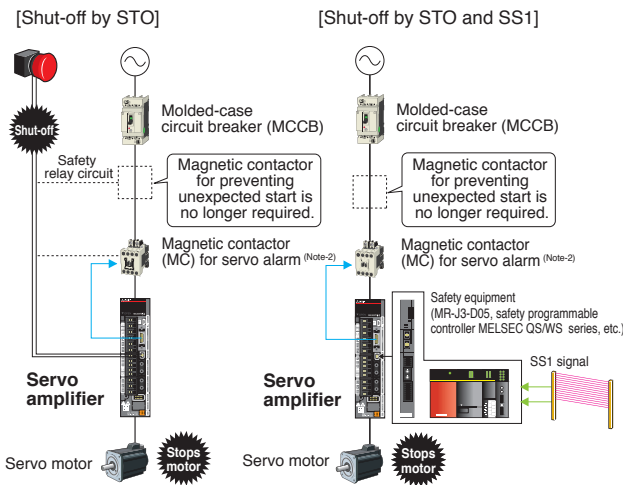

Large Capacity Drive Recorder

Patent pending Enhanced functions

- Servo data such as motor current and position command before and after the alarm occurrence are stored in non-volatile memory of the servo amplifier. The data read on MELSOFT MR Configurator2 during restoration are used for cause analysis.
- Check the waveform ((analog 16 bits × 7 channels + digital 8 channels) × 256 points) of 16 alarms in the alarm history and the monitor value.

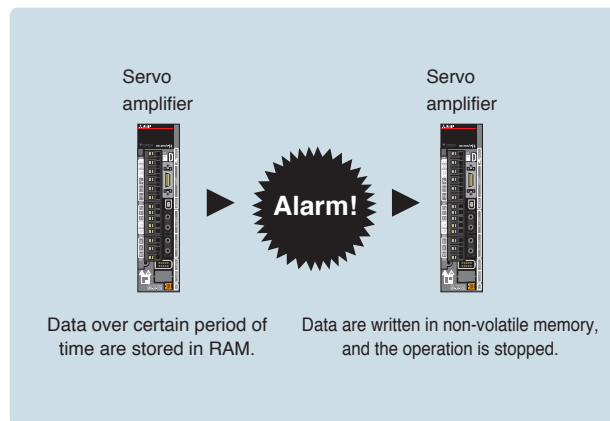

Tough Drive Function

Enhanced functions

Vibration tough drive

Machine resonance suppression filter is automatically readjusted when a change in machine resonance frequency is detected by the servo amplifier. Losses from the machine stop due to age-related deterioration are reduced.

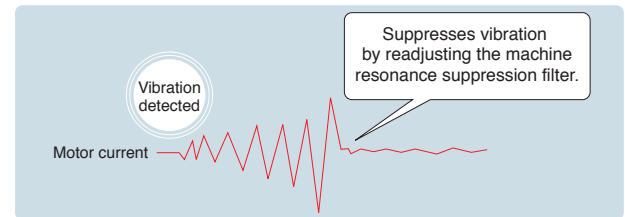

Instantaneous power failure tough drive

The possibility of undervoltage alarm is reduced when instantaneous power failure is detected in the input power.

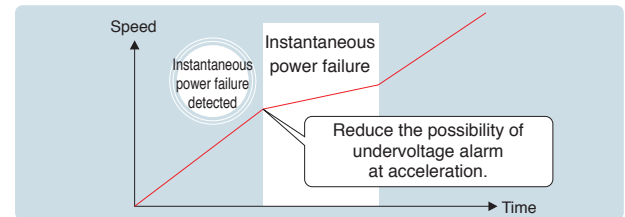

Machine Diagnosis Function

Patent pending NEW

This function detects changes of machine parts (ball screw, guide, bearing, belt, etc.) by analyzing machine friction, load moment of inertia, unbalanced torque, and changes in vibration component from the data inside the servo amplifier, supporting timely maintenance of the driving parts.

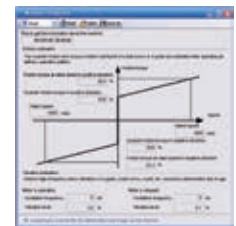

Machine diagnosis window

Servo setup software

MELSOFT MR Configurator2

Tuning, monitor display, diagnosis, reading/writing parameters, and test operations are easily performed on a personal computer. This start-up support tool achieves a stable machine system, optimum control, and short setup time.

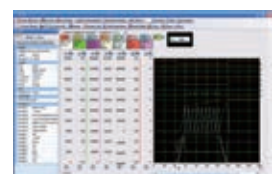

Graph window

The Environment

Space-saving with Industry's Smallest (Note) 3-axis Type

2-axis servo amplifier MR-J4W2-B requires 26% less installation space than two units of MR-J4-B. 3-axis servo amplifier MR-J4W3-B requires 30% less installation space than three units of MR-J4-B.

[Installation space: Configuration example of installing two units of 100 W, 200 W, 400 W, and 750 W each]

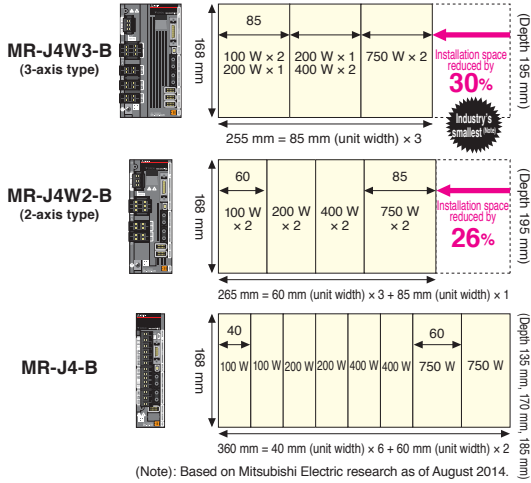

Supporting Energy-conservative Machine Using Regenerative Energy

In the multi-axis servo amplifier, the regenerative energy of an axis is used as driving power energy for the other axes, contributing to energy-conservation of machine. Reusable regenerative energy stored in the capacitor is increased for MR-J4W2-B/MR-J4W3-B as compared to the prior model. Regenerative option is no longer required (Note-1).

(Note-1): Regenerative option may be required depending on the conditions.

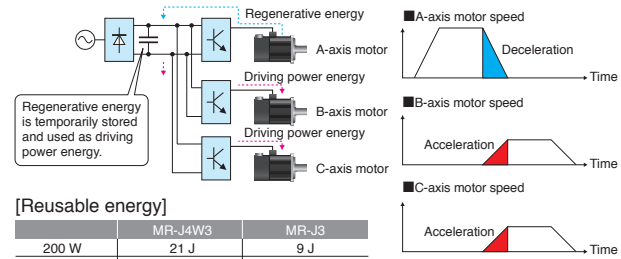

In the multi-axis servo amplifier, the amount of temporarily stored regenerative energy can be increased by using a capacitor bank. (Available in the future) Contact your local sales office for more details.

Energy-conservation Achieved by LM-H3 Linear Servo Motor Series

Reduced motor driving power

LM-H3 has achieved a reduction of 25% in motor driving current due to a new magnetic design with optimized magnet form, contributing to power conservation for machines. The motor coil is lighter as compared to the prior model, which also contributes to saving energy for driving the moving part. (Note): For 720 N rated linear servo motor.

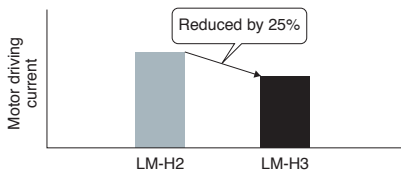

Space saving

For LM-H3, widths of the motor coil and the magnet are reduced by 10% from the prior model. Increased thrust to current ratio results in using the servo amplifier in smaller capacity, contributing to more compact machine (the reduction of materials).

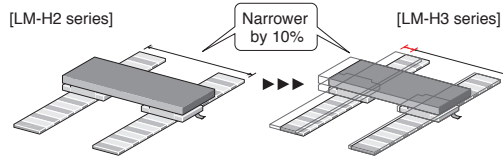

Heritage

- MR-J4-B has the same mounting dimensions (Note-1) with MR-J3-B. HG rotary servo motor series has the same mounting dimensions (Note-2) and uses the same optional cables for the power, the encoder (Note-3), and the electromagnetic brake as HF series or HC-RP/HC-UP series. (Note-1): Mounting dimensions are smaller for 200 V 5 kW, 400 V 3.5 kW, 200 V/400 V 11 kW, and 200 V/400 V 15 kW servo amplifiers. (Note-2): For a replacement of HA-LP series with HG-JR series, contact your local sales office. (Note-3): An encoder cable is incompatible with HG-JR series of 11 kW to 55 kW.

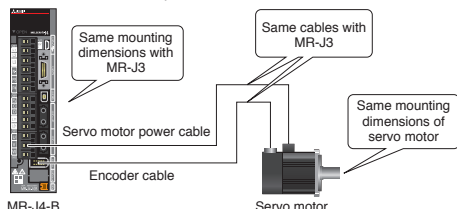

- SSCNET III/H compatible and SSCNET III compatible products can be used together.

(Note): When the SSCNET III compatible products are in the system, the communication speed is 50 Mbps, and the function and the performance are equivalent to those of MR-J3.

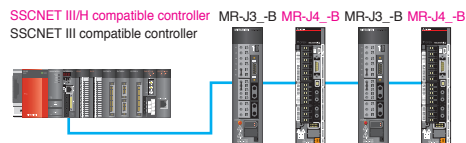

- Parameters are automatically converted by changing MR-J3-B to MR-J4-B with MELSOFT MT Works2 (Note-1). (Note-1): Update your MT Works2 to the latest version.

Outline
Motion Controller
Simple Motion
Network
Servo Amplifier
Engineering Environment

Fully supporting all your needs from model selection, system design, startup to maintenance with diverse software

Motion Controller Engineering Software
MELSOFT MT Works2

Comprehensively supporting Motion controller design and maintenance

Motion SFC programming, parameter setting, digital oscilloscope function, and simulation function are available. This software supports all necessary steps including system configuration, programming, debugging, and maintenance of Motion controllers.

Programmable Controller Engineering Software
MELSOFT GX Works2

Supporting settings of Simple Motion modules as well as sequence program creation

This software supports sequence program creation and the necessary setup steps for use of Simple Motion modules, such as the creation, startup, debugging, and maintenance of parameters, positioning data, and cam data.

Servo Setup Software
MELSOFT MR Configurator2

Startup support tool for a suitable machine system, optimum control and short setup time

Tuning, monitor display, diagnosis, reading/writing parameters, and test operations are easily performed on a personal computer. This startup support tool achieves a stable machine system, optimum control, and short setup time.

Motion Controller Engineering Software
Programmable Controller Engineering Software

MELSOFT MT Works2
MELSOFT GX Works2



System design

SSCNET settings



Servo amplifiers and modules can be set easily with a graphical system setting screen.



System configuration



Motion modules can be set easily with a graphical screen.



Servo data setting



One-point help allows parameters to be set without a manual.

The electronic gear can be set easily just by inputting the machine specifications (reduction ratio, ball screw pitch, etc.).

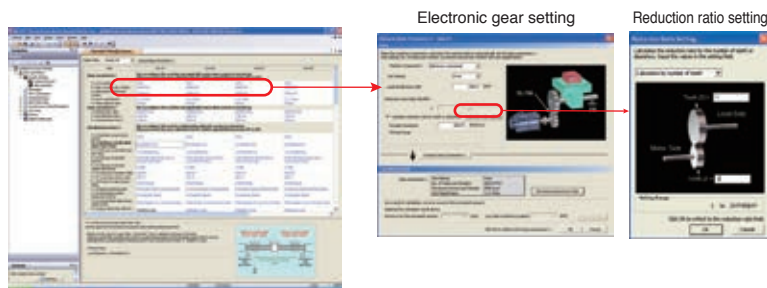

Copying servo data



Copy & paste the data between axes easily.

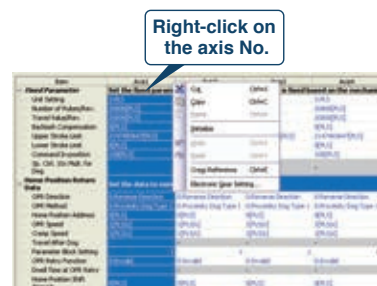

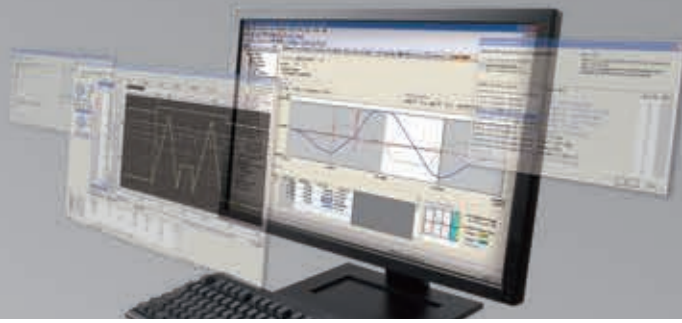

Programming

Positioning data setting

GX Works2

Functions such as Data setting assistant, and Automatic calculation of auxiliary arc simplify the setting input process of positioning data.

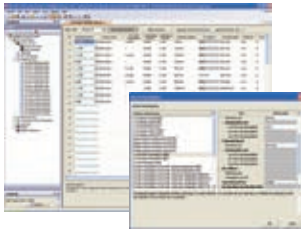

Command speed automatic calculation

GX Works2

The speed is automatically calculated by specifying the movement distance, operation time, and acceleration/deceleration time.



Programming

MT Works2

User-friendly functions facilitate Motion controller program development.



Synchronous control parameter

MT Works2

GX Works2

Using software to replace machine mechanisms, such as the gear, shaft, speed change gear and cam achieves synchronous control, just by setting parameters.



Cam data creation

MT Works2

GX Works2

Cam control has become more flexible than the conventional. Various cam patterns are created.

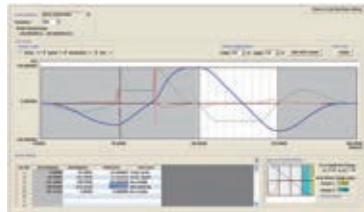

Cam data list

MT Works2

GX Works2

The created cam data are easily viewed as thumbnails.

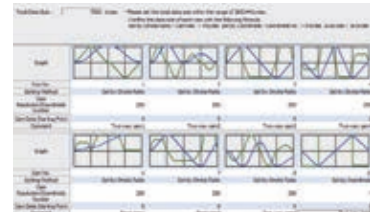

Startup and adjustment

Monitor

MT Works2

GX Works2

The items and axes to be displayed can be selected from various monitored information.

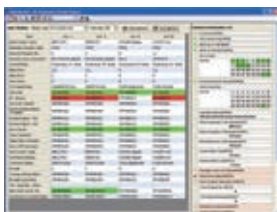

Digital oscilloscope

MT Works2

GX Works2

Operation check and troubleshooting are powerfully supported with data collection and wave displays which are synchronized to the Motion operation cycle.

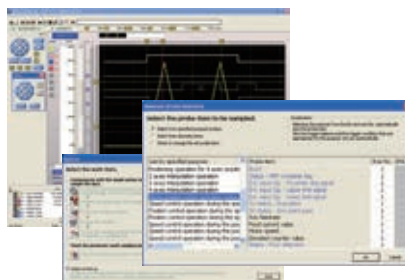

The assistant function explains all work steps. Set often-viewed data easily with the purpose-based probe setting.

Simulator

MT Works2

Program debugging can be executed without using a Motion controller, which improves designing efficiency.



Easy setup

Servo setup software **MELSOFT MR Configurator2**



MR Configurator2

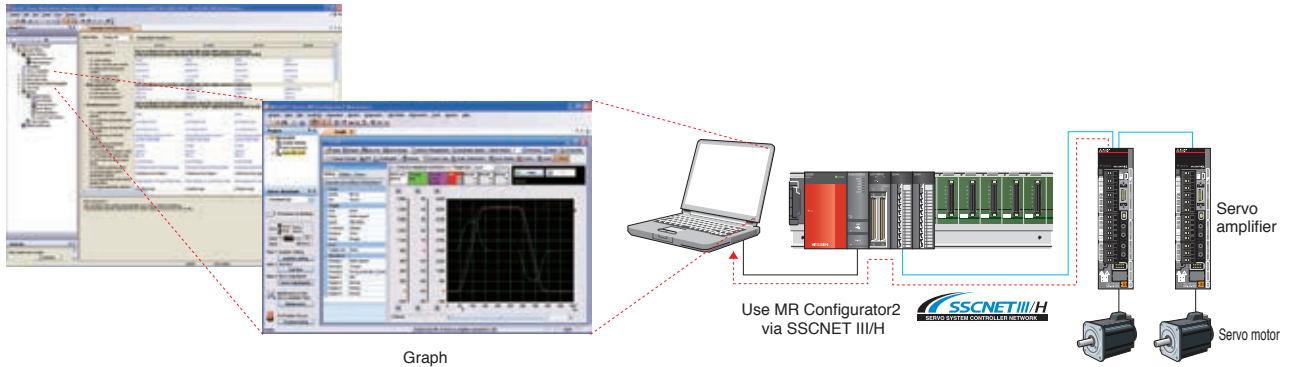

(Note):MELSOFT MR Configurator2 is included in MELSOFT MT Works2.

Setting and startup

MR Configurator2

Servo assistant function

Complete setting up the servo amplifier just by following guidance displays.

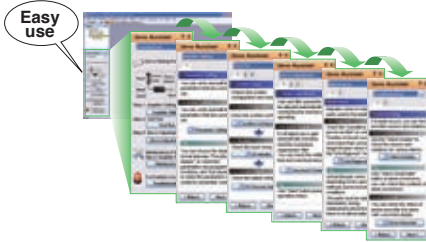

Parameter setting function

Display parameter setting in list or visual formats, and set parameters by selecting from the drop down list.

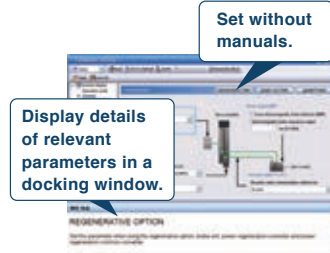

Monitor function

Monitor operation status on the [Display all] window. Measurement equipment such as electric power meter is not required since power consumption is monitored.

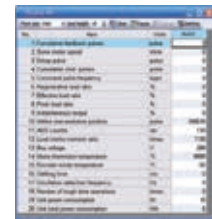

Servo adjustment

MR Configurator2

One-touch tuning function

Adjustments including estimating load to motor inertia ratio, adjusting gain, and suppressing machine resonance are automatically performed for the maximum servo performance just by clicking the start button.

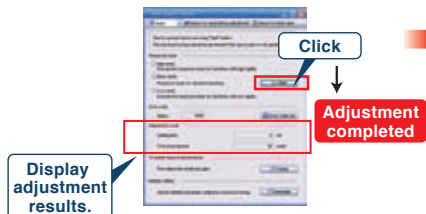

Tuning function

Adjust control gain finely on the [Tuning] window manually for further performance after the one-touch tuning.

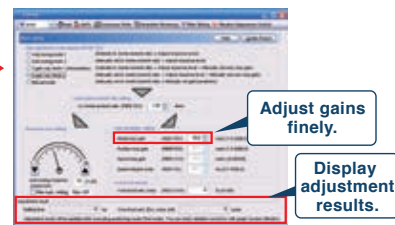

Alarm window

In MR-J4 series, servo alarms are displayed in three digits. Troubleshooting at alarm occurrence is easy.

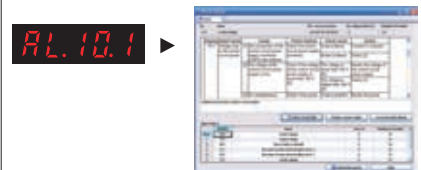

Select the most suitable motor for your machine

Capacity selection software MRZJW3-MOTSZ111E

The most suitable servo amplifier, servo motor, and regenerative option can be selected just by setting machine specifications and operation pattern. Select the operation pattern from either position control mode or speed control mode. The capacity selection software is available for free download. Contact your local sales office for more details.





Amplifier series selection



Motor series selection



Operation pattern

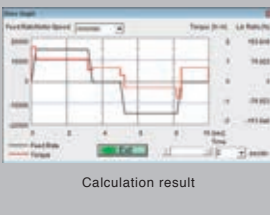

Calculation result

- Horizontal ball screws, vertical ball screws, rack and pinions, roll feeds, rotating tables, carts, elevators, conveyors, linear servo, other devices
- Prints entered specifications, operating pattern, calculation process, graph of selection process feed speed and torque, and sizing results.

Implements a seamless engineering environment

MELSOFT iQ Works

MELSOFT iQ Works

MELSOFT iQ Works is an integrated engineering software product, composing of GX Works2, MT Works2, GT Works3, and RT ToolBox2. By sharing information such as system designs and programming as the entire control system, the system design and programming efficiency are improved and total cost reduction is achieved.

MELSOFT Navigator

In combination with GX Works2, MT Works2, GT Works3, and RT ToolBox2, this software performs upstream system design and inter-software operation.

It provides such convenient functions as system configuration design, batch setting of parameters, system labeling, and batch reading.

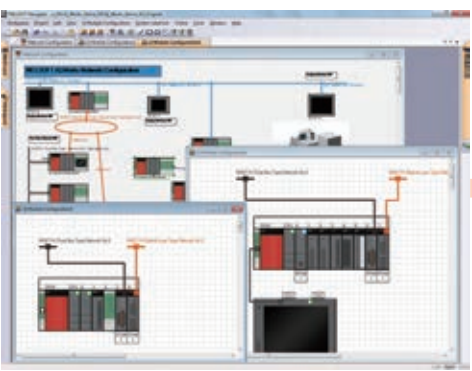





Programmable Controller
Engineering Software
MELSOFT GX Works2



Motion Controller
Engineering Software
MELSOFT MT Works2



Screen Design Software
MELSOFT GT Works3



Robot Total Engineering
Support Software
MELSOFT RT ToolBox2

MELSOFT Navigator

Outline

Motion Controller

Simple Motion

Network

Servo Amplifier

Engineering Environment

■ Motion controller software

[Engineering environment MELSOFT series]

Product	Model name	Description
MELSOFT MT Works2	SW1DND-MTW2-E	Parameter setting and program creation of Motion CPU
MELSOFT GX Works2	SW1DND-GXW2-E	Sequence program creation
MELSOFT IQ Works <small>(Note-1)</small>	SW1DNC-IQWK-E	License product (1 license in CD-ROM)
	SW1DND-IQWK-E	License product (1 license in DVD-ROM)

(Note-1): This product includes the following software.

- System Management Software [MELSOFT Navigator]
- Programmable Controller Engineering Software [MELSOFT GX Works2]
- Motion Controller Engineering Software [MELSOFT MT Works2]
- Screen Design Software [MELSOFT GT Works3]
- Robot Total Engineering Support Software [MELSOFT RT ToolBox2 mini]

[Operating environment]

MELSOFT MT Works2

Item	Description
OS	Microsoft® Windows® 8.1 (64bit/32bit), Microsoft® Windows® 8.1 (Enterprise, Pro) (64bit/32bit) Microsoft® Windows® 8 (64bit/32bit), Microsoft® Windows® 8 (Enterprise, Pro) (64bit/32bit) Microsoft® Windows® 7 (Enterprise, Ultimate, Professional, Home Premium, Starter) (64bit/32bit) Microsoft® Windows Vista® (Enterprise, Ultimate, Business, Home Premium, Home Basic) (32bit) Microsoft® Windows® XP Service Pack2 or later (Professional, Home Edition) (32bit)
CPU	Desktop: Recommended Intel® Celeron® 2.8 GHz or more Laptop: Recommended Intel® Pentium® M 1.7 GHz or more
Required memory	For 32-bit edition: Recommended 1GB or more For 64-bit edition: Recommended 2GB or more
Available hard disk capacity	When installing MT Developer2: HDD available capacity is 3GB or more. When operating MT Developer2: Virtual memory available capacity is 512MB or more.
Optical drive	DVD-ROM supported disk drive
Monitor	Resolution 1024 x 768 dots or higher

MELSOFT GX Works2

Item	Description
OS	Microsoft® Windows® 8.1 (64bit/32bit), Microsoft® Windows® 8.1 (Enterprise, Pro) (64bit/32bit) Microsoft® Windows® 8 (64bit/32bit), Microsoft® Windows® 8 (Enterprise, Pro) (64bit/32bit) Microsoft® Windows® 7 (Enterprise, Ultimate, Professional, Home Premium, Starter) (64bit/32bit) Microsoft® Windows Vista® (Enterprise, Ultimate, Business, Home Premium, Home Basic) (32bit) Microsoft® Windows® XP Service Pack2 or later (Professional, Home Edition) (32bit)
CPU	Recommended Intel® Core™2 Duo Processor 2GHz or more
Required memory	Recommended 1GB or more
Available hard disk capacity	When installing GX Works2: HDD available capacity is 2.5GB or more. When operating GX Works2: Virtual memory available capacity is 512MB or more.
Optical drive	CD-ROM supported disk drive
Monitor	Resolution 1024 x 768 dots or higher

MEMO

Outline

Motion Controller

Simple Motion

Network

Servo Amplifier

Engineering Environment

As a recognized leader in factory automation,
Mitsubishi Electric offers a world-class level of customer satisfaction.

Production/Development System

For more than 80 years from the start of operations in 1924, Mitsubishi Electric Nagoya Works has manufactured various universal devices including motors, programmable controllers and inverters. The history of AC servo production at Nagoya Works spans over 30 years. We have expanded our production system based on the technology and tradition amassed during this time, and have incorporated world-class research and development to create high-performance, high-quality products that can be supplied for a long time.

Production system

To guarantee the high quality and performance of MELSERVO, Mitsubishi Electric has built a cooperative system of three facilities - Shinshiro Factory, a branch factory of Nagoya Works; Mitsubishi Electric Automation Manufacturing (Changshu) Co., Ltd., a manufacturing base; and Nagoya Works at the core. Mitsubishi Electric responds to various needs throughout the world by uniting technologies and know-how of these facilities. Mitsubishi Electric's FA energy solutions, "e&eco-F@ctory", are at work in the servo motor factory at the Nagoya Works. They are being used to boost capacity utilization and product quality, and reduce energy consumption.

Development system

To spread advanced servo systems to the world as quickly as possible, Mitsubishi Electric has established FA-related development centers at its Nagoya Works, and in North America and Europe. Furthermore, we have established strong connections between our Advanced Technology R&D Center, which pushes technology development beyond the limits of FA, and Information Technology R&D Center. We are moving forward with the development of new products that reflect the latest technological directions and customer input.



Mitsubishi Electric Nagoya Works



FA Development Center



e&eco-F@ctory implementation



EDC (Europe Development Center)

Promoting the popularity of SSCNET in Japan and around the world

SSCNET Partner Association

The SSCNET Partner Association (SNP) acting to spread SSCNET throughout the world.



The SSCNET Partner Association (SNP) carries activities to introduce the advanced servo system controller network "SSCNET" and compatible products to many users. In cooperation with partner corporations, SNP widely promotes the performance attainable with SSCNET. In recent years, SNP holds partner meetings in Japan and other countries such as Taiwan and India. SNP aims to make "SSCNET" a more global servo system controller network.

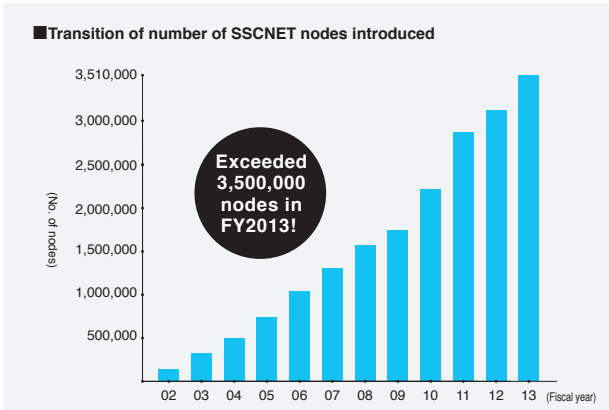

"SSCNET" increases the freedom of system configurations with the Mitsubishi servo as well as the variety of SSCNET compatible partner products including stepping motors and direct drive motors.

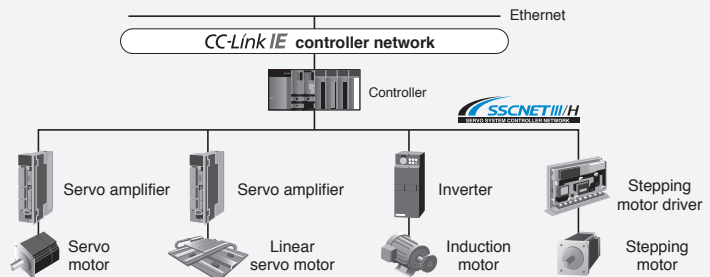

Main membership benefits

- Access to the latest trends and information on motion network SSCNET and Mitsubishi Electric FA businesses
- Participation in partner meetings in Japan and overseas
- Expanding business opportunities
- Introduction of member products and SSCNET compatible products to various tools and media
- SNP membership requires no joining fees or annual dues.

Members of The SSCNET Partner Association (in alphabetical order)

Asahi Engineering Co., Ltd.	GMC Hillstone Co., Ltd.	Hamamatsu Photonics K.K.	Harmonic Drive Systems Inc.	HOKUYO AUTOMATIC CO., LTD.	IAI Corporation
Mitsubishi Electric Corporation	Mitsubishi Electric Engineering Co., Ltd.	Murata Machinery, Ltd.	Nikki Denso Co., Ltd.	NIPPON THOMPSON CO., LTD.	NSD Corporation
ORIENTAL MOTOR Co., Ltd.	SANYO DENKI CO., LTD.	ShinMaywa Industries, Ltd.	TESSERA TECHNOLOGY INC.	THK CO., LTD.	238 corporations in Japan and other countries

A global support network for MELSERVO users

Global FA Center

Across the globe, FA Centers provide customers with local assistance for purchasing Mitsubishi Electric products and with after-sales service. To enable national branch offices and local representatives to work together in responding to local needs, we have developed a service network throughout the world. We provide repairs, on-site engineering support, and sales of replacement parts. We also provide various services from technical consulting services by our expert engineers to practical training for equipment operations.



Ratingen, Germany
Germany FA Center/
Europe Development Center



Krakowska, Poland
Europe FA Center (Poland)



St. Petersburg, Russia
Russia FA Center



**Pune/Gurgaon/Bangalore/
Chennai/Ahmadabad, India**
India FA Center



Bangkok, Thailand
Thailand FA Center



Hatfield, U.K.
UK FA Center



Praha, Czech Republic
Czech Republic FA Center



Istanbul, Turkey
Turkey FA Center



China (including Hong Kong District)



Beijing, China
Beijing FA Center



Tianjin, China
Tianjin FA Center



Guangzhou, China
Guangzhou FA Center

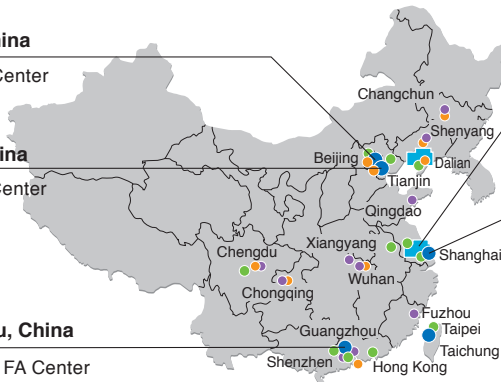

Changshu, China

China Local Factory
Mitsubishi Electric
Automation Manufacturing
(Changshu) Co., Ltd.



Shanghai, China

Shanghai FA Center



Complies with EN, UL, CSA (c-UL) standards,
and Korea Radio Wave Law (KC).



Servo system controllers conform to global standards.

- * This product is not subject to China Compulsory Certification (CCC).
- * Refer to "Servo Amplifier Instruction Manual" and "EMC Installation Guidelines" when your system needs to meet the EMC directive.
- * For corresponding standards and models, contact your local sales office.

- Global FA Center ● FA Center Satellite (China) ● Mechatronics Service Base (China) ● Mitsubishi Sales Offices
- Production Facility ◆ Development Center



Complies with Restriction of Hazardous Substances Directive (RoHS).

Human and environment-friendly Mitsubishi servo system controllers are compliant with RoHS Directive.

About RoHS directive
 RoHS Directive requires member nations to guarantee that new electrical and electronic equipment sold in the market after July 1, 2006 do not contain lead, cadmium, mercury, hexavalent chromium, polybrominated biphenyl (PBB) and polybrominated diphenyl ether (PBDE) flame retardants. <G> mark indicating RoHS Directive compliance is printed on the package.

(Note): Refer to "Servo Amplifier Instruction Manual" and "EMC Installation Guidelines" when your system needs to meet the EMC directive.

Our optional cables and connectors comply with "Measures for Administration of the Pollution Control of Electronic Information Products" (Chinese RoHS).

Global FA Centers

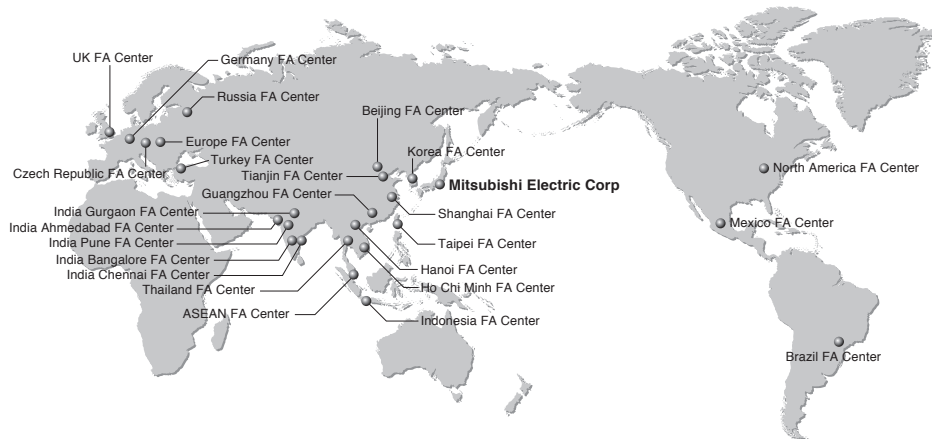

China

Shanghai FA Center
MITSUBISHI ELECTRIC AUTOMATION (CHINA) LTD.
 No.1386 Hongqiao Road,
 Mitsubishi Electric Automation Center,
 Shanghai, China
 Tel: 86-21-2322-3030 Fax: 86-21-2322-3000 (9611#)

Beijing FA Center
MITSUBISHI ELECTRIC AUTOMATION (CHINA) LTD. Beijing Branch
 Unit 901, 9F, Office Tower 1, Henderson Centre,
 18 Jianguomennei Avenue, Dongcheng District,
 Beijing, China
 Tel: 86-10-6518-8830 Fax: 86-10-6518-2938

Tianjin FA Center
MITSUBISHI ELECTRIC AUTOMATION (CHINA) LTD. Tianjin Branch
 Room 2003 City Tower, No.35, Youyi Road,
 Hexi District, Tianjin, China
 Tel: 86-22-2813-1015 Fax: 86-22-2813-1017

Guangzhou FA Center
MITSUBISHI ELECTRIC AUTOMATION (CHINA) LTD. Guangzhou Branch
 Room 1609, North Tower, The Hub Center,
 No.1068, Xingang East Road, Haizhu District,
 Guangzhou, China
 Tel: 86-20-8923-6730 Fax: 86-20-8923-6715

Taiwan

Taipei FA Center
SETSUYO ENTERPRISE CO., LTD.
 3F, No.105, Wugong 3rd Road, Wugu District,
 New Taipei City 24889, Taiwan, R.O.C.
 Tel: 886-2-2299-9917 Fax: 886-2-2299-9963

Korea

Korea FA Center
MITSUBISHI ELECTRIC AUTOMATION KOREA CO., LTD.
 7F-9F, Gangseo Hangang Xi-tower A, 401,
 Yangcheon-ro, Gangseo-Gu, Seoul 157-801, Korea
 Tel: 82-2-3660-9630 Fax: 82-2-3663-0475

Thailand

Thailand FA Center
MITSUBISHI ELECTRIC FACTORY AUTOMATION (THAILAND) CO., LTD.
 12th Floor, SV.City Building, Office Tower 1,
 No. 896/19 and 20 Rama 3 Road,
 Kwaeng Bangpongpan, Khet Yannawa, Bangkok
 10120, Thailand
 Tel: 66-2682-6522 to 6531 Fax: 66-2682-6020

ASEAN

ASEAN FA Center
MITSUBISHI ELECTRIC ASIA PTE. LTD.
 307, Alexandra Road, Mitsubishi Electric Building,
 Singapore 159943
 Tel: 65-6470-2480 Fax: 65-6476-7439

Indonesia

Indonesia FA Center
PT. MITSUBISHI ELECTRIC INDONESIA Cikarang Office
 Jl. Kenari Raya Blok G2-07A Delta Silicon 5,
 Lippo Cikarang - Bekasi 17550, Indonesia
 Tel: 62-21-2961-7797 Fax: 62-21-2961-7794

Vietnam

Hanoi FA Center
MITSUBISHI ELECTRIC VIETNAM COMPANY LIMITED Hanoi Branch
 6 - Floor, Detech Tower, 8 Ton That Thuyet Street,
 My Dinh 2 Ward, Nam Tu Liem District, Hanoi,
 Vietnam
 Tel: 84-4-3937-8075 Fax: 84-4-3937-8076

Ho Chi Minh FA Center
MITSUBISHI ELECTRIC VIETNAM COMPANY LIMITED
 Unit 01-04, 10th Floor, Vincom Center, 72 Le
 Thanh Ton Street, District 1, Ho Chi Minh City,
 Vietnam
 Tel: 84-8-3910-5945 Fax: 84-8-3910-5947

India

India Pune FA Center
MITSUBISHI ELECTRIC INDIA PVT. LTD. Pune Branch
 Emerald House, EL -3, J Block, M.I.D.C Bhosari,
 Pune - 411026, Maharashtra, India
 Tel: 91-20-2710-2000 Fax: 91-20-2710-2100

India Gurgaon FA Center
MITSUBISHI ELECTRIC INDIA PVT. LTD. Gurgaon Head Office
 2nd Floor, Tower A & B, Cyber Greens, DLF
 Cyber City, DLF Phase - III, Gurgaon - 122002
 Haryana, India
 Tel: 91-124-463-0300 Fax: 91-124-463-0399

India Bangalore FA Center
MITSUBISHI ELECTRIC INDIA PVT. LTD. Bangalore Branch
 Prestige Emerald, 6th Floor, Municipal No. 2,
 Madras Bank Road (Lavelle Road), Bangalore -
 560001, Karnataka, India
 Tel: 91-80-4020-1600 Fax: 91-80-4020-1699

India Chennai FA Center
MITSUBISHI ELECTRIC INDIA PVT. LTD. Chennai Branch
 "Citilights Corporate Centre" No.1,
 Vivekananda Road, Srinivasa Nagar, Chetpet,
 Chennai - 600031, Tamil Nadu, India
 Tel: 91-44-4554-8772 Fax: 91-44-4554-8773

India Ahmedabad FA Center
MITSUBISHI ELECTRIC INDIA PVT. LTD. Ahmedabad Branch
 B/4, 3rd Floor, Safal Profitaire, Corporate Road,
 Prahaldnagar, Satellite, Ahmedabad,
 Gujarat - 380015, India
 Tel: 91-79-6512-0063 Fax: 91-79-6512-0063

America

North America FA Center
MITSUBISHI ELECTRIC AUTOMATION, INC.
 500 Corporate Woods Parkway, Vernon Hills,
 IL 60061, U.S.A.
 Tel: 1-847-478-2100 Fax: 1-847-478-2253

Mexico

Mexico FA Center
MITSUBISHI ELECTRIC AUTOMATION, INC. Mexico Branch
 Mariano Escobedo #69, Col. Zona Industrial,
 Tlalnepantla Edo, C.P.54030, Mexico
 Tel: 52-55-3067-7511 Fax: -

Brazil

Brazil FA Center
MITSUBISHI ELECTRIC DO BRASIL COMÉRCIO E SERVIÇOS LTDA.
 Rua Jussara, 1750- Bloco B Anexo, Jardim Santa
 Cecilia, CEP 06465-070, Barueri - SP, Brasil
 Tel: 55-11-4689-3000 Fax: 55-11-4689-3016

Europe

Europe FA Center
MITSUBISHI ELECTRIC EUROPE B.V. Polish Branch
 ul. Krakowska 50, 32-083 Balice, Poland
 Tel: 48-12-630-47-00 Fax: 48-12-630-47-01

Germany FA Center
MITSUBISHI ELECTRIC EUROPE B.V. German Branch
 Gothaer Strasse 8, D-40880 Ratingen, Germany
 Tel: 49-2102-486-0 Fax: 49-2102-486-1120

UK FA Center
MITSUBISHI ELECTRIC EUROPE B.V. UK Branch
 Travellers Lane, Hatfield, Hertfordshire, AL10
 8XB, U.K.
 Tel: 44-1707-28-8780 Fax: 44-1707-27-8695

Czech Republic FA Center
MITSUBISHI ELECTRIC EUROPE B.V. Czech Branch
 Avenir Business Park, Radlicka 751/113e,
 158 00 Praha5, Czech Republic
 Tel: 420-251-551-470 Fax: 420-251-551-471

Russia FA Center
MITSUBISHI ELECTRIC EUROPE B.V. Russian Branch St. Petersburg office
 Piskarevsky pr. 2, bld 2, lit "Sch", BC "Benua",
 office 720; 195027, St. Petersburg, Russia
 Tel: 7-812-633-3497 Fax: 7-812-633-3499

Turkey FA Center
MITSUBISHI ELECTRIC TURKEY A.Ş Ümraniye Branch
 Şerifali Mahallesi Nutuk Sokak No:5,
 TR-34775 Ümraniye, İstanbul, Turkey
 Tel: 90-216-526-3990 Fax: 90-216-526-3995

FA Products

PLC

MELSEC iQ-R Series

Revolutionary, next generation controllers building a new era in automation

- ◎High-speed, high-accuracy multiple CPU control system based on the iQ Platform
- ◎New high-speed system bus and inter-module sync realizes improved productivity and reduced TCO*
- ◎Reducing development costs through intuitive engineering (GX Works3)
- ◎Robust security features (such as security key authentication, IP filter)



Product Specifications

Program capacity	40K steps to 1200K steps
LD instruction speed	0.98 ns
Available modules	I/O, analog, high-speed counter, positioning, simple motion, network module
Control system architecture	Rack-mounted modular based system
Supported networks	Ethernet, CC-Link IE Control Network, CC-Link IE Field Network, CC-Link, RS-232, RS-422/485

*Total Cost of Ownership

HMI

Graphic Operation Terminal GOT2000 Series GT27 Model

To the top of HMIs with further user-friendly, satisfactory standard features.

- ◎Comfortable screen operation even if high-load processing (e.g. logging, device data transfer) is running. (Monitoring performance is twice faster than GT16)
- ◎Actual usable space without using a SD card is expanded to 128MB for more flexible screen design.
- ◎Multi-touch features, two-point press, and scroll operations for more user-friendliness.
- ◎Outline font and PNG images for clear, beautiful screen display.



Product Specifications

Screen size	15", 12.1", 10.4", 8.4"
Resolution	XGA, SVGA, VGA
Intensity adjustment	32-step adjustment
Touch panel type	Analog resistive film
Built-in interface	RS-232, RS-422/485, Ethernet, USB, SD card
Applicable software	GT Works3
Input power supply voltage	100 to 240VAC (+10%, -15%), 24VDC (+25%, -20%)

Inverter

FR-A800 Series

High-functionality, high-performance inverter

- ◎Realize even higher responsiveness during real sensor-less vector control or vector control, and achieve faster operating frequencies.
- ◎The latest automatic tuning function supports various induction motors and also sensor-less PM motors.
- ◎The standard model is compatible with EU Safety Standards STO (PLd, SIL2). Add options to support higher level safety standards.
- ◎Control and monitor inverters via CC-Link/CC-Link IE Field Network (option interface).



Product Specifications

Inverter capacity	200V class: 0.4kW to 90kW, 400V class: 0.4kW to 500kW
Control method	High-carrier frequency PWM control (Select from V/F, advanced magnetic flux vector, real sensorless vector or PM sensorless vector control), vector control (when using options)
Output frequency range	0.2 to 590Hz (when using V/F control or advanced magnetic flux vector control)
Regenerative braking torque (Maximum allowable duty)	200V class: 0.4K to 1.5K (150% at 3%ED) 2.2K/3.7K (100% at 3%ED) 5.5K/7.5K (100% at 2%ED) 11K to 55K (20% continuous) 75K or more (10% continuous), 400V class: 0.4K to 7.5K (100% at 2%ED) 11K to 55K (20% continuous) 75K or more (10% continuous)
Starting torque	200% 0.3Hz (3.7K or less), 150% 0.3Hz (5.5K or more) (when using real sensorless vector, vector control)

FA Products

Low Voltage Circuit Breakers | Mitsubishi WS-V Series Molded Case Circuit Breakers, Earth Leakage Circuit Breakers



Technologies based on long year experience realize more improved performance.

- ◎The new electronic circuit breakers can display various measurement items.
- ◎Improvement of breaking performance with new breaking technology “Expanded ISTAC”.
- ◎Compliance with global standard for panel and machine export.
- ◎Commoditization of internal accessories for shorter delivery time and stock reduction.

Product Specifications.

Frame	32-250A Frame
Applicable standard	Applicable to IEC, GB, UL, CSA, JIS and etc.
Expansion of UL listed product line-up	New line-up of 480VAC type with high breaking performance for SCCR requirement
Commoditization of internal accessories	Reduction of internal accessory types from 3 to 1
Commoditization for AC and DC circuit use	Common use of 32/63A frame in both AC and DC circuit
Compact size for easy to use	Thermal adjustable and electronic circuit breakers are same size as 250AF fixed type
Measuring Display Unit (MDU) breakers	MDU breakers measure, display and transmit energy date to realize energy management.

Magnetic Starter | MS-T Series



Exceed your expectations.

- ◎10A frame model is over 16% smaller with a width of just 36mm!!
- ◎New integrated terminal covers.
- ◎Reduce your coil inventory by up to 50%.
- ◎Be certified to the highest international levels while work is ongoing to gain other country.

Product specifications

Frame	10 A to 32 A
Applicable standards	Certification to various standards including IEC, JIS, CE, UL, TÜV, CCC.
Terminal cover	Standard terminal cover improves safety, simplifies ordering, and reduces inventory, etc.
Improved wiring	Wiring and operability are improved with streamlining wiring terminal BC specifications.
Operation coil rating	Wide range of operation coil ratings reduces number of coil types from 14 (N Series) to 7 types and simplifies selection.
Option units	Diverse lineup includes Auxiliary Contact Block, Operation Coil Surge Absorber Unit, Mechanical Interlock Unit.

Robot | MELFA F Series



High speed, high precision and high reliability industrial robot

- ◎Compact body and slim arm design, allowing operating area to be expanded and load capacity increased.
- ◎The fastest in its class using high performance motors and unique driver control technology.
- ◎Improved flexibility for robot layout design considerations.
- ◎Optimal motor control tuning set automatically based on operating position, posture, and load conditions.

Product Specifications

Degrees of freedom	Vertical:6 Horizontal:4
Installation	Vertical:Floor-mount, ceiling mount, wall mount (Range of motion for J1 is limited) Horizontal:Floor-mount
Maximum load capacity	Vertical:2-20kg Horizontal:3-20kg
Maximum reach radius	Vertical:504-1503mm Horizontal:350-1,000mm

High-grade model equipped with advanced complete nano control

- ◎Achieve complete nano control with the latest RISC-CPU and high-speed optical servo network.
- ◎Realize super-high grade processing by combining the complete nano control, state-of-the-art SSS control and OMR control, etc.
- ◎Display of essential information of grouped on three screens to greatly reduce processing setup time with easy operability.
- ◎The M700VW Series with WindowsXPe and M700VS Series with integrated control unit and display type are available.



Product Specifications

Maximum number of control axes (NC axes + spindles + PLC axes)	16 axes (M720VW/M720VS have 12 axes)
Maximum number of part systems	Machining center system: 2 systems Lathe system: 4 systems
Least command increment	1nm (M720VW/M720VS 0.1 μ m)
Least control increment	1nm
Maximum program capacity	2,000KB (5,120m)
Maximum PLC program capacity	128,000 steps
Main functions (for machining center)	Simultaneous 5-axis machining, SSS control, high-speed high-accuracy control, tool nose point control, tilt plane machining, etc.
Main functions (for lathe)	Milling interpolation, 2-system simultaneous thread cutting, inter-system control axis synchronization, control axis superimposition, combination control, etc.

Premium Efficiency & Compatible. New Launch of Super Line Premium Series SF-PR Model

- ◎Compared to general-purpose motor SF-JR model, generated loss is reduced by 37% on average, and it is compatible with highly efficient premium IE3.
- ◎Easy replacement is achieved as mounting dimension (frame number) is compatible with general-purpose motor SF-JR model.
- ◎One motor can accommodate different power sources of Japan and the U.S. Three ratings in Japan meet the Top Runner standards, while it corresponds to EISA in the U.S.
- ◎Can be driven by inverters as standard. Advanced magnetic-flux vector control by our FR-A800/700 achieves steady torque drive up to 0.5Hz.



Product Specifications

Number of poles	2-poles, 4-poles, 6-poles
Voltage·Frequency	200/200/220/230V 50/60/60/60Hz EISA 230V 60Hz or 400/400/440/460V 50/60/60/60Hz EISA 460V 60Hz
Exterior	Totally enclosed fan cooled type (inside, outside installation)
Protection system	IP44
Electrically-driven power system	Motor with 2-poles over 11kW is dedicated for a direct connection. Motors with 4-poles and 6-poles are for both direct and crossed belt connections.
Rotation direction	Counter-clock-wise (CCW) direction viewed from the edge of axis.
Compatible standard	JEC-2137-2000 (Efficiency is compatible with IEC 60034-30.)

MEMO

Lined writing area with 20 horizontal lines.

Warranty

1. Warranty period and coverage

We will repair any failure or defect (hereinafter referred to as "failure") in our FA equipment (hereinafter referred to as the "Product") arisen during warranty period at no charge due to causes for which we are responsible through the distributor from which you purchased the Product or our service provider. However, we will charge the actual cost of dispatching our engineer for an on-site repair work on request by customer in Japan or overseas countries. We are not responsible for any on-site readjustment and/or trial run that may be required after a defective unit is repaired or replaced.

[Term]

The term of warranty for Product is thirty six (36) months after your purchase or delivery of the Product to a place designated by you or forty two (42) months from the date of manufacture whichever comes first ("Warranty Period"). Warranty period for repaired Product cannot exceed beyond the original warranty period before any repair work.

[Limitations]

- (1) You are requested to conduct an initial failure diagnosis by yourself, as a general rule.
It can also be carried out by us or our service company upon your request and the actual cost will be charged.
However, it will not be charged if we are responsible for the cause of the failure.
- (2) This limited warranty applies only when the condition, method, environment, etc. of use are in compliance with the terms and conditions and instructions that are set forth in the instruction manual and user manual for the Product and the caution label affixed to the Product.
- (3) Even during the term of warranty, the repair cost will be charged on you in the following cases;
 - (i) a failure caused by your improper storing or handling, carelessness or negligence, etc., and a failure caused by your hardware or software problem
 - (ii) a failure caused by any alteration, etc. to the Product made on your side without our approval
 - (iii) a failure which may be regarded as avoidable, if your equipment in which the Product is incorporated is equipped with a safety device required by applicable laws and has any function or structure considered to be indispensable according to a common sense in the industry
 - (iv) a failure which may be regarded as avoidable if consumable parts designated in the instruction manual, etc. are duly maintained and replaced
 - (v) any replacement of consumable parts (battery, electrolytic capacitor, etc.)
 - (vi) a failure caused by external factors such as inevitable accidents, including without limitation fire and abnormal fluctuation of voltage, and acts of God, including without limitation earthquake, lightning and natural disasters
 - (vii) a failure generated by an unforeseeable cause with a scientific technology that was not available at the time of the shipment of the Product from our company
 - (viii) any other failures which we are not responsible for or which you acknowledge we are not responsible for

2. Term of warranty after the stop of production

- (1) We may accept the repair at charge for another seven (7) years after the production of the product is discontinued. The announcement of the stop of production for each model can be seen in our Sales & Service, etc.
- (2) Please note that the Product (including its spare parts) cannot be ordered after its stop of production.

3. Service in overseas

Our regional FA Center in overseas countries will accept the repair work of the Product; however, the terms and conditions of the repair work may differ depending on each FA Center. Please ask your local FA center for details.

4. Exclusion of responsibility for compensation against loss of opportunity, secondary loss, etc.

Whether under or after the term of warranty, we assume no responsibility for any damages arisen from causes for which we are not responsible, any losses of opportunity and/or profit incurred by you due to a failure of the Product, any damages, secondary damages or compensation for accidents arisen under a specific circumstance that are foreseen or unforeseen by our company, any damages to products other than the Product, and also compensation for any replacement work, readjustment, start-up test run of local machines and the Product and any other operations conducted by you.

5. Change of Product specifications

Specifications listed in our catalogs, manuals or technical documents may be changed without notice.

6. Application and use of the Product

- (1) For the use of our Servo System Controller, its applications should be those that may not result in a serious damage even if any failure or malfunction occurs in Servo System Controller, and a backup or fail-safe function should operate on an external system to Servo System Controller when any failure or malfunction occurs.
- (2) Our Servo System Controller is designed and manufactured as a general purpose product for use at general industries. Therefore, applications substantially influential on the public interest for such as atomic power plants and other power plants of electric power companies, and also which require a special quality assurance system, including applications for railway companies and government or public offices are not recommended, and we assume no responsibility for any failure caused by these applications when used.
In addition, applications which may be substantially influential to human lives or properties for such as airlines, medical treatments, railway service, incineration and fuel systems, man-operated material handling equipment, entertainment machines, safety machines, etc. are not recommended, and we assume no responsibility for any failure caused by these applications when used.
We will review the acceptability of the abovementioned applications, if you agree not to require a specific quality for a specific application. Please contact us for consultation.

Microsoft, Windows, Internet Explorer, and Windows Vista are either registered trademarks or trademarks of Microsoft Corporation in the United States and/or other countries. Celeron and Pentium are registered trademarks of Intel Corporation in the U.S. and/or other countries.

Ethernet is a trademark of Xerox Corporation.

All other company names and product names used in this document are trademarks or registered trademarks of their respective companies.



Safety Warning

To ensure proper use of the products listed in this catalog, please be sure to read the instruction manual prior to use.

SERVO SYSTEM CONTROLLERS

Country/Region	Sales office	Tel/Fax
USA	MITSUBISHI ELECTRIC AUTOMATION, INC. 500 Corporate Woods Parkway, Vernon Hills, IL 60061, U.S.A.	Tel : +1-847-478-2100 Fax : +1-847-478-2253
Mexico	MITSUBISHI ELECTRIC AUTOMATION, INC. Mexico Branch Mariano Escobedo #69, Col. Zona Industrial, Tlalnepantla Edo, C.P.54030, Mexico	Tel : +52-55-3067-7500 Fax : -
Brazil	MITSUBISHI ELECTRIC DO BRASIL COMÉRCIO E SERVIÇOS LTDA. Rua Jussara, 1750- Bloco B Anexo, Jardim Santa Cecilia, CEP 06465-070, Barueri - SP, Brasil	Tel : +55-11-4689-3000 Fax : +55-11-4689-3016
Germany	MITSUBISHI ELECTRIC EUROPE B.V. German Branch Gothaer Strasse 8, D-40880 Ratingen, Germany	Tel : +49-2102-486-0 Fax : +49-2102-486-1120
UK	MITSUBISHI ELECTRIC EUROPE B.V. UK Branch Travellers Lane, Hatfield, Hertfordshire, AL10 8XB, U.K.	Tel : +44-1707-28-8780 Fax : +44-1707-27-8695
Italy	MITSUBISHI ELECTRIC EUROPE B.V. Italian Branch Centro Direzionale Colleoni - Palazzo Sirio Viale Colleoni 7, 20864 Agrate Brianza(Milano) Italy	Tel : +39-039-60531 Fax : +39-039-6053-312
Spain	MITSUBISHI ELECTRIC EUROPE, B.V. Spanish Branch Carretera de Rubí, 76-80-Apdo. 420, 08173 Sant Cugat del Vallés (Barcelona), Spain	Tel : +34-935-65-3131 Fax : +34-935-89-1579
France	MITSUBISHI ELECTRIC EUROPE B.V. French Branch 25, Boulevard des Bouvets, F-92741 Nanterre Cedex, France	Tel : +33-1-55-68-55-68 Fax : +33-1-55-68-57-57
Czech Republic	MITSUBISHI ELECTRIC EUROPE B.V. Czech Branch Avenir Business Park, Radlicka 751/113e, 158 00 Praha5, Czech Republic	Tel : +420-251-551-470 Fax : +420-251-551-471
Poland	MITSUBISHI ELECTRIC EUROPE B.V. Polish Branch ul. Krakowska 50, 32-083 Balice, Poland	Tel : +48-12-630-47-00 Fax : +48-12-630-47-01
Russia	MITSUBISHI ELECTRIC EUROPE B.V. Russian Branch St. Petersburg office Piskarevsky pr. 2, bld 2, lit "Sch", BC "Benua", office 720; RU-195027 St. Petersburg, Russia	Tel : +7-812-633-3497 Fax : +7-812-633-3499
Sweden	MITSUBISHI ELECTRIC EUROPE B.V. (Scandinavia) Fjelievägen 8, SE-22736 Lund, Sweden	Tel : +46-8-625-10-00 Fax : +46-46-39-70-18
Turkey	MITSUBISHI ELECTRIC TURKEY A.Ş Ümraniye Branch Şerifali Mahallesi Nutuk Sokak No:5, TR-34775 Ümraniye, İstanbul, Turkey	Tel : +90-216-526-3990 Fax : +90-216-526-3995
UAE	MITSUBISHI ELECTRIC EUROPE B.V. Dubai Branch Dubai Silicon Oasis, P.O.BOX 341241, Dubai, U.A.E.	Tel : +971-4-3724716 Fax : +971-4-3724721
South Africa	ADROIT TECHNOLOGIES 20 Waterford Office Park, 189 Witkoppen Road, Fourways, Johannesburg, South Africa	Tel : +27-11-658-8100 Fax : +27-11-658-8101
China	MITSUBISHI ELECTRIC AUTOMATION (CHINA) LTD. No.1386 Hongqiao Road, Mitsubishi Electric Automation Center, Shanghai, China	Tel : +86-21-2322-3030 Fax : +86-21-2322-3000
Taiwan	SETSUYO ENTERPRISE CO., LTD. 6F, No.105, Wugong 3rd Road, Wugu District, New Taipei City 24889, Taiwan, R.O.C.	Tel : +886-2-2299-2499 Fax : +886-2-2299-2509
Korea	MITSUBISHI ELECTRIC AUTOMATION KOREA CO., LTD. 7F-9F, Gangseo Hangang Xi-tower A, 401, Yangcheon-ro, Gangseo-Gu, Seoul 157-801, Korea	Tel : +82-2-3660-9510 Fax : +82-2-3664-8372/8335
Singapore	MITSUBISHI ELECTRIC ASIA PTE. LTD. 307, Alexandra Road, Mitsubishi Electric Building, Singapore 159943	Tel : +65-6473-2308 Fax : +65-6476-7439
Thailand	MITSUBISHI ELECTRIC FACTORY AUTOMATION (THAILAND) CO., LTD. 12th Floor, SV.City Building, Office Tower 1, No. 896/19 and 20 Rama 3 Road, Kwaeng Bangpongpan, Khet Yannawa, Bangkok 10120, Thailand	Tel : +66-2682-6522 to 6531 Fax : +66-2682-6020
Indonesia	PT. MITSUBISHI ELECTRIC INDONESIA Gedung Jaya 11th Floor, JL. MH. Thamrin No.12, Jakarta Pusat 10340, Indonesia	Tel : +62-21-3192-6461 Fax : +62-21-3192-3942
Vietnam	MITSUBISHI ELECTRIC VIETNAM COMPANY LIMITED Unit 01-04, 10th Floor, Vincom Center, 72 Le Thanh Ton Street, District 1, Ho Chi Minh City, Vietnam	Tel : +84-8-3910-5945 Fax : +84-8-3910-5947
India	MITSUBISHI ELECTRIC INDIA PVT. LTD. Pune Branch Emerald House, EL -3, J Block, M.I.D.C Bhosari, Pune - 411026, Maharashtra, India	Tel : +91-20-2710-2000 Fax : +91-20-2710-2100
Australia	MITSUBISHI ELECTRIC AUSTRALIA PTY. LTD. 348 Victoria Road, P.O. Box 11, Rydalmere, N.S.W 2116, Australia	Tel : +61-2-9684-7777 Fax : +61-2-9684-7245

Mitsubishi Electric Corporation Nagoya Works is a factory certified for ISO14001 (standards for environmental management systems) and ISO9001(standards for quality assurance management systems)



MITSUBISHI ELECTRIC CORPORATION

HEAD OFFICE: TOKYO BUILDING, 2-7-3, MARUNOUCHI, CHIYODA-KU, TOKYO 100-8310, JAPAN
NAGOYA WORKS: 1-14, YADA-MINAMI 5, HIGASHI-KU, NAGOYA, JAPAN